

# TOOL CATALOG

No.211

*WE DESIGN TOOLS TO MAKE CUSTOMERS' WORK AND LIFE CONVENIENT.  
WE MAKE A CONCERTED EFFORT FOR INNOVATION.  
WE CONTINUE TO IMPROVE THE QUALITY OF OUR PRODUCTS.  
WE SINCERELY RECOMMEND OUR PRODUCTS TO CONSUMERS AND BUSINESSES.*





# For Your Safety

## Spanners

- Use the correct tool for a bolt or nut.
- Please insert a spanner or wrench all the way into the bolt or nut and engage properly.
- A tool might slip and come off from a bolt or nut when it is strained too hard.
- Do not insert a pipe or other object to extend the tool.
- Do not hit a tool with a hammer or other objects, except for impact tools such as box-ended and single-ended wrenches.
- For your safety, please wear safety goggles, earplugs, safety hats and safety footwear when using impact tools such as box-ended and single-ended wrenches.
- Please be careful not to get your fingers caught in the hole of the handle.
- Do not use if a tool is cracked, worn away, or deformed.
- Do not utilize a tool as a hammer.

## Hexagon Key Wrenches

- Use the correct tool for a bolt or nut.
- Please insert a hex key all the way into a hexagon bolt and engage properly.
- A tool might slip and come off from a bolt or nut when it is strained too hard.
- Do not insert a pipe or other object to extend the tool.
- Do not use if a tool is cracked, worn away, or deformed.
- Do not hit a tool with a hammer or other objects.
- Do not utilize a tool as a hammer.

## Torque Wrenches

- Use the correct tool for a bolt or nut.
- Please insert a spanner or wrench all the way into the bolt or nut and engage properly.
- A tool might slip and come off from a bolt or nut when it is strained too hard.
- Please completely insert square drive.
- Do not exceed the maximum torque.
- Do not use to loosen bolts or nuts.
- Do not insert a pipe or other object to extend the tool.
- Do not use if a tool is cracked, worn away, or deformed.
- Do not hit a tool with a hammer or other objects.
- Do not utilize a tool as a hammer.
- Please read the instructions carefully before use.
- Please perform regular calibration to keep the tools accurate.

## Sockets

- Use the correct tool for a bolt or nut.
- Please insert a spanner or wrench all the way into the bolt or nut and engage properly.
- A tool might slip and come off from a bolt or nut when it is strained too hard.
- Please completely insert square drive.
- Please use dedicated sockets and accessories for power tools such as impact wrenches.
- For your safety, please wear safety goggles, earplugs, safety hats and safety footwear when using impact wrenches.
- Do not use if a tool is cracked, worn away, or deformed.
- Do not hit a tool with a hammer or other objects.
- Do not utilize a tool as a hammer.
- Please use a specified O-ring or pin and set on an impact wrench securely.
- Do not connect more than two extension bars or adapters.

## T-Handled, Y-Shape, Tire Wrenches

- Use the correct tool for a bolt or nut.
- Please insert a spanner or wrench all the way into the bolt or nut and engage properly.
- A tool might slip and come off from a bolt or nut when it is strained too hard.
- Do not insert a pipe or other object to extend the tool.
- Do not use if a tool is cracked, worn away, or deformed.
- Do not hit a tool with a hammer or other objects.
- Do not utilize a tool as a hammer.

## Pliers

- Please be careful not to get your hands or fingers caught in a handgrip.
- Please adjust and set an opening of pliers correctly.
- Do not use if a tool is cracked, worn away, or deformed.
- Do not hit a tool with a hammer or other objects.
- Do not utilize a tool as a hammer.

## Hammer

- For your safety, please wear safety goggles, earplugs, safety hats and safety footwear.
- Do not use if the tool is unstable, cracked, worn away or deformed.
- Please hit the striking surface vertically.



## 90 years of manufacturing useful, high-quality tools

In the 90 years or more since our company was founded, we have worked to improve our hot forging technology—essential for the manufacture of tough, robust tools—in the manufacture of high-quality spanners, combination spanners, and ring spanners, as we have strived to develop innovative products with unique value. We will continue to manufacture high quality tools that are useful to people, always seeking to reach greater heights as one of Japan's leading tool manufacturers.

## A Beautiful Shape Comes from Lightness

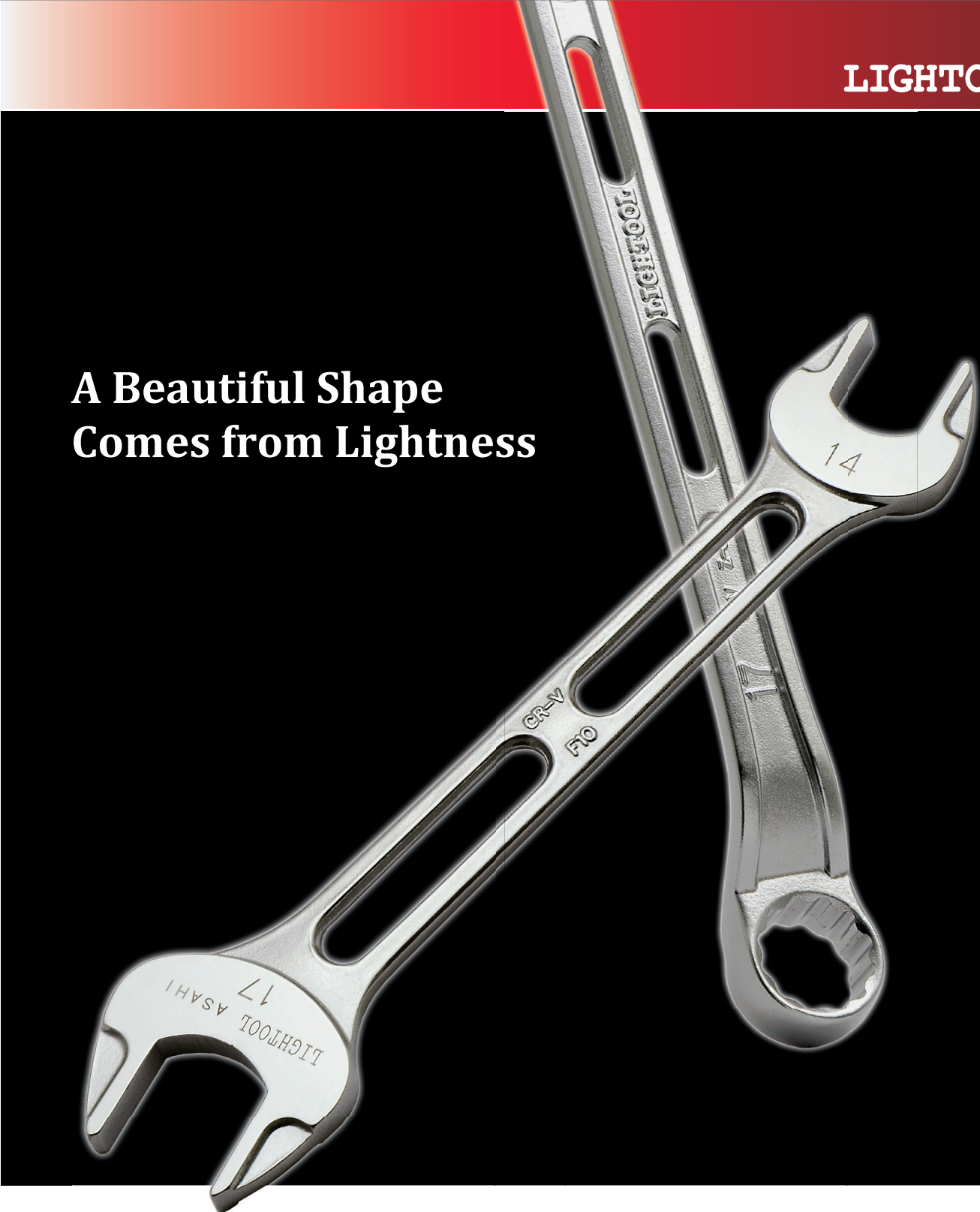

### Lightweight Yet Durable

Highly portable and workable tools are suitable for work in high places or for long periods of use. Tested design and high-quality forging technology have produced lightweight yet durable tools, which meet the JIS regulations.

Comparison with our conventional products

Size	Normal	LIGHTOOL	Percentage
5.5 × 7	30g	10g	67%
8 × 10	30g	15g	50%
11 × 13	50g	40g	20%
12 × 14	70g	50g	29%
17 × 19	120g	100g	17%
22 × 24	215g	180g	16%

### A Uniquely Shaped Head



A uniquely shaped head is lightweight yet durable. (LSX/LCW/LCWU)

### A Wide Range of Sizes and Shapes

- LSX Double Open End Spanner 11 sizes (5.5×7mm—22×24mm)
- LOF Offset Wrench 10 sizes (8×10mm—22×24mm)
- LCW Combination Wrench 14 sizes (5.5mm—24mm)
- LCWU Combination Wrench 6 sizes (8mm—17mm)
- LVR Ratchet Handle 5 type (□9.5mm, □12.7mm)

### A Compact Head

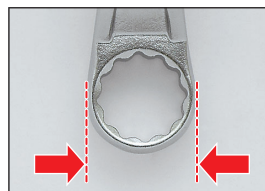

A ring spanner head is smaller than ever before and suitable for working in confined spaces. (LOF)

# ASAHI's New Generation Tools



## Innovative Design

A sleek, timeless design with a streamlined curved surface of a neck and a tapered shape head. A handle and a head make a beautiful contrast.



## High Workability

The curved surface of the neck fits your hand and produces great workability.

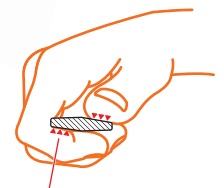

Easy-to-grasp-handle

## A Wide Range of Sizes and Shapes

- SL Double Open End Spanner 13sizes (5.5×7mm—22×24mm)
- CL Combination Wrench 20sizes (5.5mm—32mm)
- OL Offset Wrench 8sizes (8×10mm—22×24mm)
- VRL Ratchet Handle 2type (□9.5mm, □12.7mm)

Identify the wrench  
to a particular size  
by color

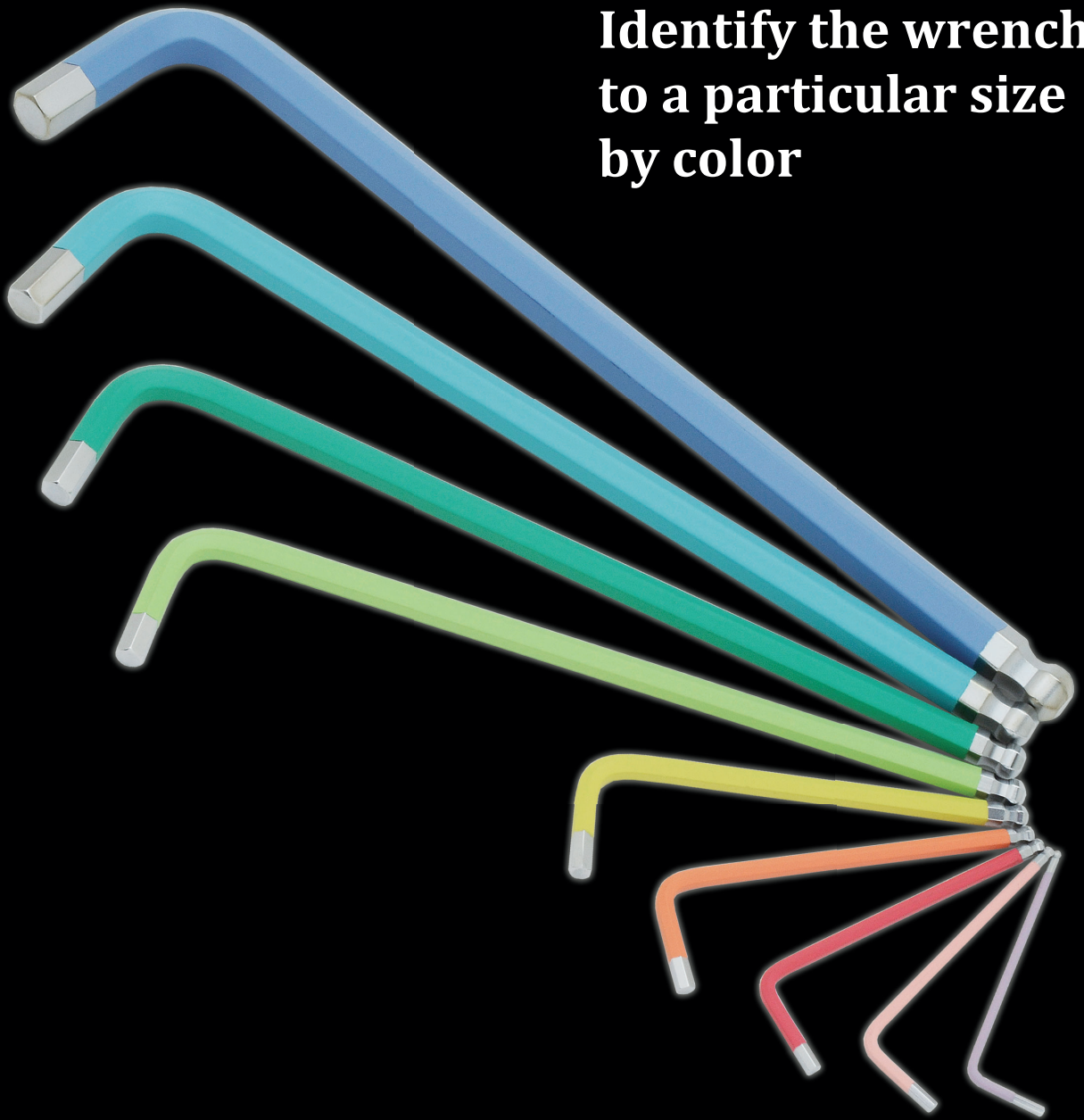

### Different Colors For Each Size

Painted with different colors to recognize the sizes without checking measurement labels on the hex keys.

Baked finish with excellent durability

Original color for high visibility

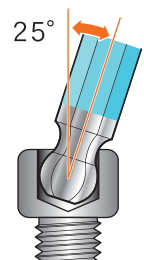
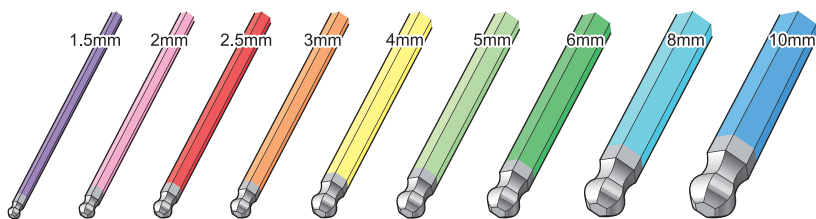

# Suitable for Working in Confined Spaces



## Double-Ended Hex Keys

This product only requires only 30 degrees turning angle (half of normal space), as both ends are bent twisted 90 degrees opposite angle. Please use the both end interchangeably to work continuously.

(DY/DZ)

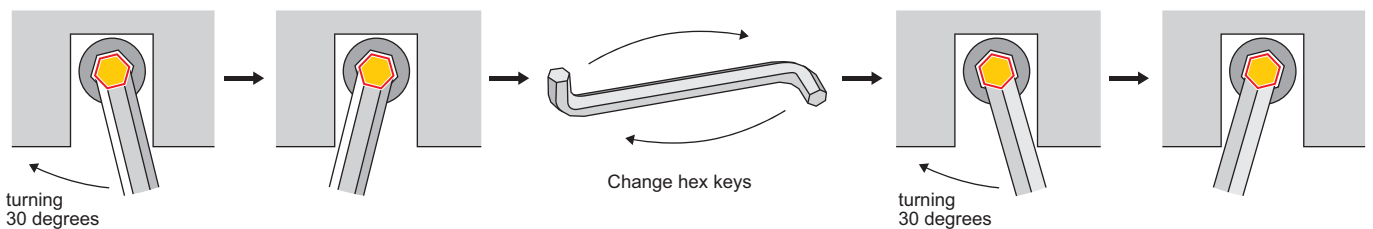
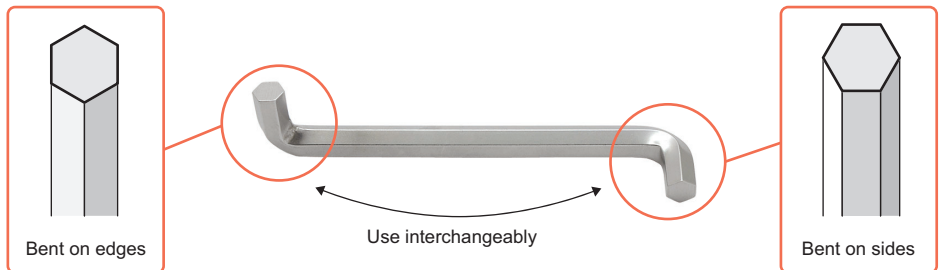



## Anti-Drop Hex Keys



### Catcherball

A spring suspension and a steel ball implanted by a high-precision processing technology holds the bolt securely. The bolt is firmly secured and does not need to be held by a hand before or after tightening, or during work in an inaccessible place.

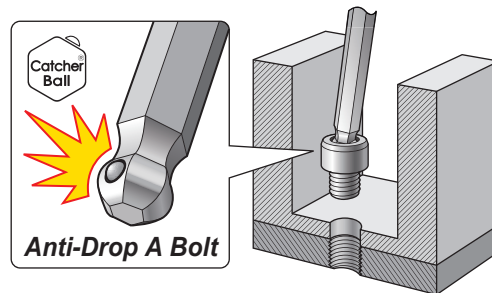

# The Definitive Collection of Plumbing Tools

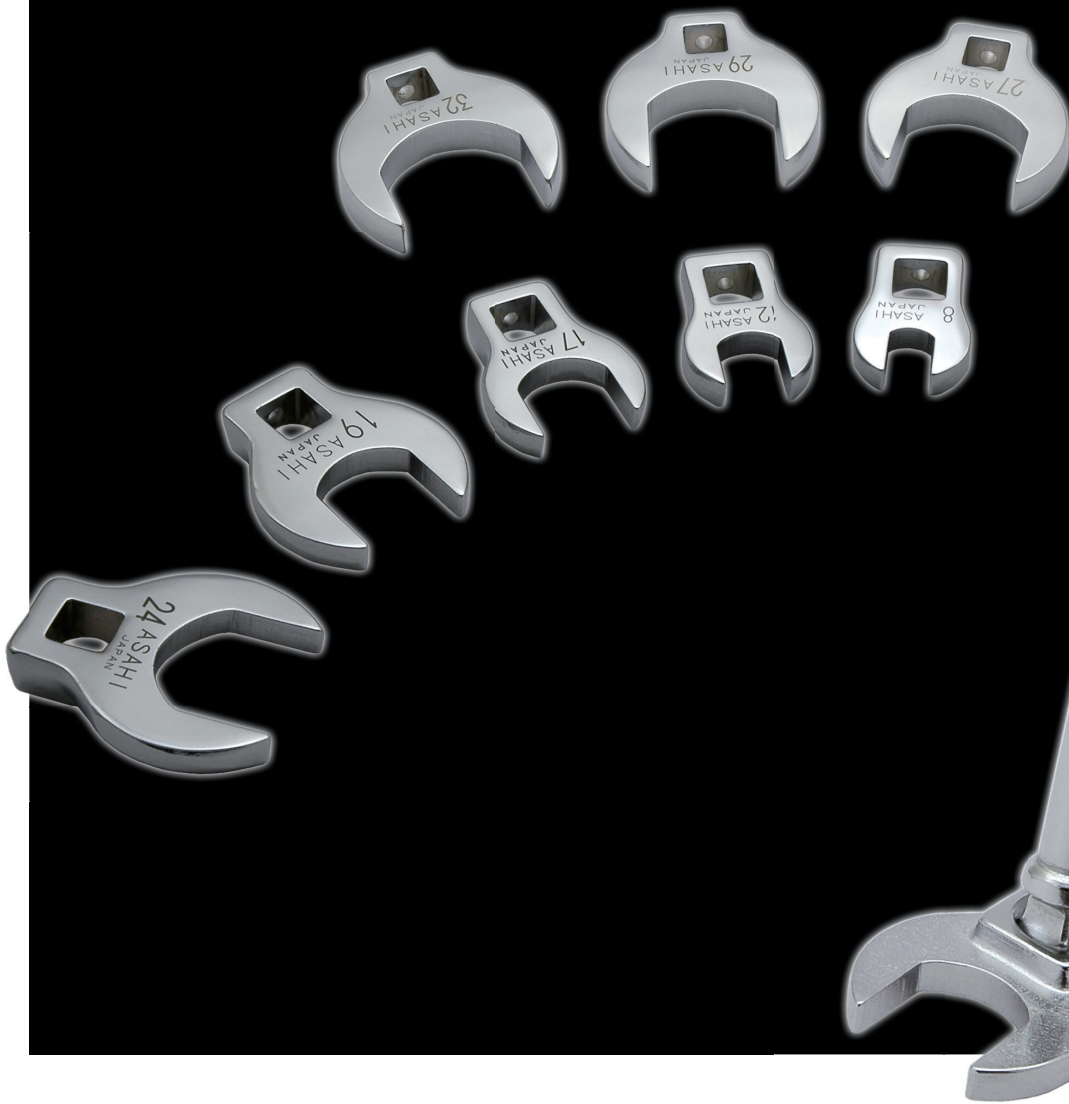

## Suitable for Working in Narrow and Confined Spaces

Suitable for car pipes or machine plumbing.

- For air conditioner, power steering, and brake hydraulic plumbing
- For various kinds of sensors in difficult places
- For maintenance of hydraulic plumbing inside machines
- For other kinds of plumbing

## A Wide Range of Sizes and Shapes

- □6.3mm      7sizes (5.5mm—13mm)
- □9.5mm      18sizes (8mm—32mm)
- □12.7mm    13sizes (17mm—60mm)

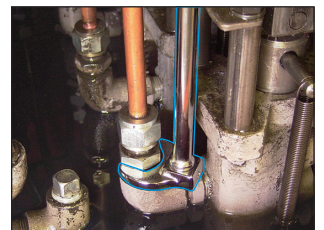
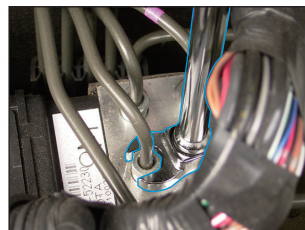

**New item**

**SSP Single Open End Spanner, Metric**

Code	mm	C mm	T mm	L mm	Weight g	Box	Price ¥
SSP0005	5.5	17	3.2	82	10	10	730
SSP0006	6	17	3.2	82	10	10	730
SSP0007	7	20	4	92	20	10	730
SSP0008	8	20	4	92	20	10	730
SSP0009	9	24	4.5	105	30	10	830
SSP0010	10	24	4.5	105	30	10	780
SSP0011	11	29	5.5	122	40	10	830
SSP0012	12	29	5.5	122	50	10	790
SSP0013	13	33	6.2	135	50	10	790
SSP0014	14	33	6.2	135	60	10	840
SSP0017	17	39	7.7	165	100	10	910
SSP0019	19	43	8.2	177	120	10	980
SSP0021	21	49	9.5	200	160	10	1,340
SSP0022	22	49	9.5	200	150	10	1,520
SSP0023	23	53	10.5	220	220	10	1,760
SSP0024	24	53	10.5	220	220	10	1,700
SSP0026	26	59	11.5	245	290	10	1,730
SSP0027	27	59	11.5	245	300	10	1,890
SSP0029	29	66	12.5	275	440	10	2,450
SSP0030	30	68	12.5	275	440	10	2,340
SSP0032	32	68	12.5	275	430	10	2,340
SSP0035	35	80	14.5	315	520	5	3,530
SSP0036	36	80	14.5	315	600	5	3,460
SSP0038	38	80	14.5	315	610	5	4,600
SSP0041	41	90	16	360	850	5	4,300
SSP0046	46	102	18.5	410	1,340	5	5,700
SSP0050	50	102	18.5	410	1,340	5	7,300
SSP0055	55	117	20	470	1,840	2	11,600
SSP0060	60	130	22	530	2,510	2	18,700
SSP0065	65	130	22	530	2,480	2	24,000
SSP0070	70	143	24	575	3,230	2	32,100
SSP0075	75	161	24	645	3,950	2	35,000

Nickel chrome plated type added



- Heavy Duty
- Nickel Chrome Plating

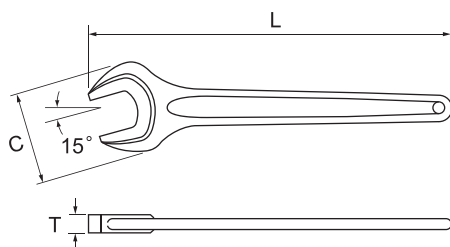

## RD Ring Spanner, Metric

Code	mm	D mm	T mm	L mm	Weight g	Box	Price ¥
RD0017	17	27	23.5	212.5	148	5	1,800
RD0019	19	32	25	233	190	5	2,040
RD0021	21	33	25.5	241.5	194	5	2,280
RD0022	22	33.5	25.5	249	214	5	2,280
RD0024	24	37	29	261.5	277	5	2,360

- Nickel Chrome Plating

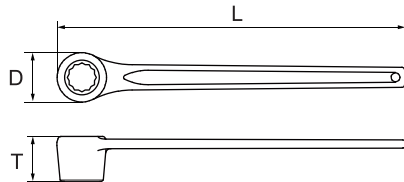

### Deep-type ring spanner released



## SS Single Open End Spanner, Metric

Code	mm	C mm	T mm	L mm	Weight g	Box	Price ¥
SS0016	16	39	7.7	165	100	10	930
SS0018	18	43	8.2	177	120	10	960

- Heavy Duty
- Cathodic Electrodeposition

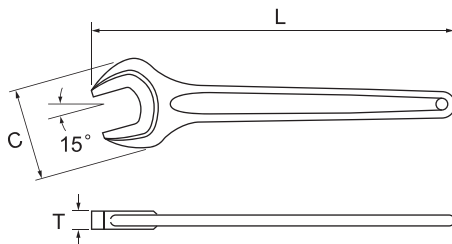

### Two product sizes added



## DR Striking Face Ring Spanner, Metric

Code	mm	D mm	T mm	t mm	L mm	Weight g	Box	Price ¥
DR0038	38	66	22	16	223	940	2	6,300

- Cathodic Electrodeposition

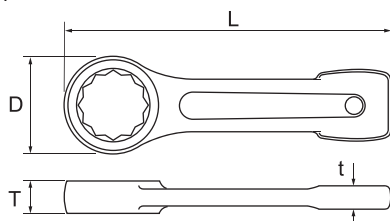



### One product sizes added



# New item

## DRX Striking Face Ring Spanner, Inch

Code	 Inch	D mm	T mm	t mm	L mm	Weight g		Price ¥
DRX1516	15/16	45	18	13.5	185	340	2	7,000
DRX0101	1	45	18	13.5	185	340	2	7,000
DRX1716	1-1/16	45	18	13.5	185	340	2	7,000
DRX0908	1-1/8	55	20	15	197	520	2	8,200
DRX0504	1-1/4	55	20	15	197	520	2	8,200
DRX2116	1-5/16	55	20	15	197	520	2	8,200
DRX1108	1-3/8	55	20	15	197	520	2	8,200
DRX2316	1-7/16	66	22	16	223	940	2	9,400
DRX0302	1-1/2	66	22	16	223	940	2	9,400
DRX1308	1-5/8	66	22	16	223	940	2	9,400
DRX2716	1-11/16	80	27	18	250	1,330	2	13,000
DRX0704	1-3/4	80	27	18	250	1,330	2	13,000
DRX2916	1-13/16	80	27	18	250	1,330	2	13,000
DRX1508	1-7/8	80	27	18	250	1,330	2	13,000
DRX0201	2	80	27	18	250	1,330	2	13,000

- Cathodic Electrodeposition

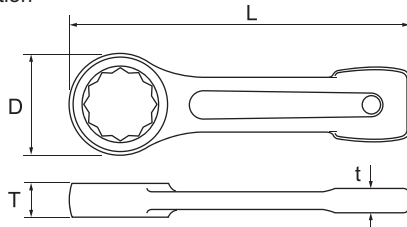

inch

Inch sizes added



## DA Striking Face Spanner with Hex Bit, Metric

Code	 mm	D mm	T mm	t mm	L mm	Weight g	Price ¥
DA1400	14	55	60	15	197	760	24,500
DA1700	17	55	60	15	197	780	24,500
DA4100	41	90	82	19	275	2,830	42,000
DA4600	46	90	82	19	275	2,980	42,000

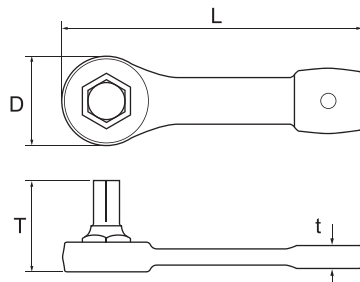

- Cathodic Electrodeposition
- Interchangeable
- Special Order



Four product sizes added



## FP Hook Spanner, Pin Type

Code	 mm	d mm	ℓ mm	T mm	H mm	L mm	Weight g		Price ¥
FP8592	85~92	5.5	6	8.5	62	270	390	10	3,150

- Cathodic Electrodeposition

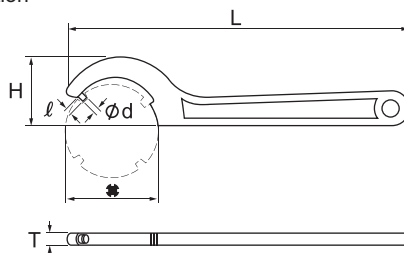

One product sizes added



**New item**

**AQUS Long Ball Point Hexagon Key Wrench Set**

**7Pcs.**

1.5 mm 2 mm 2.5 mm 3 mm 4 mm 5 mm 6 mm

Code	mm	Weight g		Price ¥
AQUS710	AQU-1.5, 2, 2.5, 3, 4, 5, 6	140	10	7,250

- Plastic Holder
- Blister pack 240 × 75 × 15mm

7-piece set added

**Auroline®**



**AZU Ball Point Hexagon Key Wrenches**

Code	mm	L mm	ℓ mm	Weight g		Price ¥
AZU0150	1.5	50	14	1	-	730
AZU0200	2	56	16	1.8	-	730
AZU0250	2.5	63	18	3.2	-	750
AZU0300	3	71	20	5.4	-	750
AZU0400	4	80	22	10	-	780
AZU0500	5	90	25	18	-	880
AZU0600	6	100	28	30	-	1,040
AZU0800	8	112	32	62	-	1,380
AZU1000	10	125	36	110	-	1,810

- Special Alloy Steel ( ~ 0600)
- Alloy Steel (0800 ~ )
- Nickel Chrome Plating
- Baking Finish

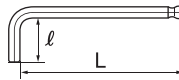

Short type released

**Auroline®**

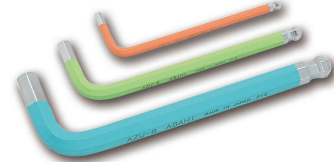

**7Pcs.**

1.5 mm 2 mm 2.5 mm 3 mm 4 mm 5 mm 6 mm

Code	mm	Weight g		Price ¥
AZUS710	AZU-1.5, 2, 2.5, 3, 4, 5, 6	100	10	6,500

- Plastic Holder
- Blister pack 165 × 75 × 15mm



**9Pcs.**

1.5 mm 2 mm 2.5 mm 3 mm 4 mm 5 mm 6 mm 8 mm 10 mm

Code	mm	Weight g		Price ¥
AZUS910	AZU-1.5, 2, 2.5, 3, 4, 5, 6, 8, 10	280	5	9,650

- Plastic Holder
- Blister pack 190 × 90 × 25mm



# New item

## AQTS Long Ball Point Hexagon Key Wrench Set

9Pcs.

1.5 mm 2 mm 2.5 mm 3 mm 4 mm 5 mm 6 mm 8 mm 10 mm

9-piece set with connecting holder released

Code	mm	Weight g	Box	Price ¥
AQTS910	AQ-1.5, 2, 2.5, 3, 4, 5, 6, 8, 10	430	1	12,000

- Connect Holder
- Casing 305 × 65 × 35mm

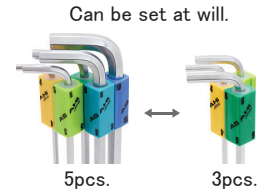
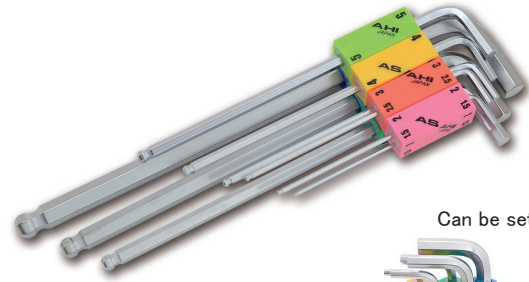

## AQKX Long Ball Point Hexagon Key Wrench with Holding Ball Type

Code	inch	L mm	ℓ mm	Weight g	Box	Price ¥
AQKX108	1/8	126	20	10	10	970
AQKX532	5/32	142	23	17	10	1,090
AQKX316	3/16	160	28	29	10	1,270
AQKX104	1/4	180	32	57	10	1,630
AQKX516	5/16	200	36	98	10	2,040
AQKX308	3/8	224	40	160	10	3,020

- Special Alloy Steel ( ~ AQKX316 )
- Alloy Steel (AQKX104 ~ )
- Nickel Chrome Plating

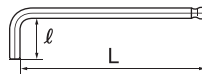

inch Inch model released



9Pcs.

1/16 5/64 3/32 1/8 5/32 3/16 1/4 5/16 3/8  
without Catcher Ball with Catcher Ball



Code	inch	Weight g	Box	Price ¥
AQKSE91	AQX-1/16, 5/64, 3/32 AQKX-1/8, 5/32, 3/16, 1/4, 5/16, 3/8	400	5	14,200

- Plastic Holder
- Blister pack 265 × 90 × 30mm

## LCS Open End Head

Open End Head

Code	mm	mm	effective length ℓ mm	B mm	h mm	H mm	L mm	Weight g	Box	Price ¥
LCS0207	7	10	45	29	7	16	55	57	1	2,660
LCS0208	8	10	45	29	7	16	55	56	1	2,660
LCS0209	9	10	45	29	7	16	55	56	1	2,660
LCS0210	10	10	45	29	7	16	55	56	1	2,660
LCS0211	11	10	45	29	7	16	55	53	1	2,660
LCS0212	12	10	45	32	7	16	55.5	57	1	2,840
LCS0213	13	10	45	32	7	16	55.5	57	1	2,840
LCS0214	14	10	45	32	7	16	55.5	56	1	2,840
LCS0217	17	10	45	39	8	16	57.5	72	1	3,020
LCS0219	19	10	45	39	8	16	57.5	69	1	3,020
LCS0221	21	10	45	39	8	16	57.5	65	1	3,020
LCS0222	22	10	45	39	8	16	57.5	63	1	3,020
LCS0224	24	10	45	45	8	16	60	78	1	7,000
LCS0227	27	10	45	45	8	16	60	72	1	7,000

- Nickel Chrome Plating

Torque wrench with 10 mm insertion diameter added

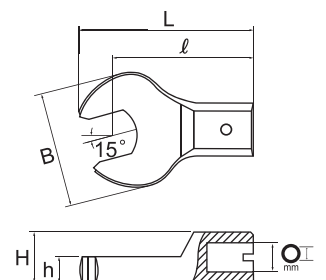

**LCX Hexagon Head, Metric**

Code	mm	mm	effective length l mm	h mm	H mm	L mm	Weight g		Price ¥
LCX0225	2.5	10	45	27	16	46.3	56	1	3,900
LCX0203	3	10	45	29	16	46.5	55	1	3,900
LCX0204	4	10	45	35	16	47	55	1	4,000
LCX0205	5	10	45	38	16	47.5	55	1	4,100
LCX0206	6	10	45	43	16	48	56	1	4,100
LCX0208	8	10	45	48	16	49	60	1	4,200

- Body : Cathodic Electrodeposition
- Hex : Black Oxide Finish

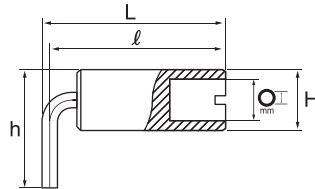

Torque wrench with 10 mm insertion diameter added



**LQ Ratchet Head**

Code	mm	mm	effective length l mm	b mm	h mm	H mm	L mm	Weight g		Price ¥
LQ3045	9.5	10	45	31	14	16	60	116	1	7,920

- Nickel Chrome Plating

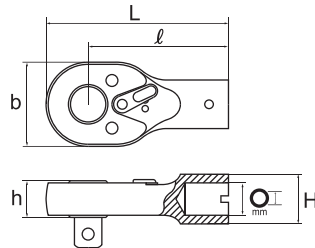

Torque wrench with 10 mm insertion diameter added



**LC Torque Wrench, Pre-set Type, with Tool Carrier for Insert Tool**

Code	Torque Range N · m	mm	effective length l mm	L mm	Weight g		Price ¥
LC023N	5~25	10	190	208	200	1	16,900

5-25 N · m torque range type added

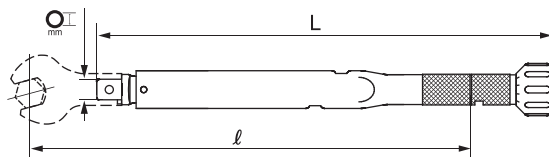

**LCQ Torque Wrench with Ratchet Head, with Tool Carrier for Insert Tool**

Code	Torque Range N · m	mm	mm	effective length l mm	b mm	h mm	L mm	Weight g		Price ¥
LCQ023N	5~25	10	9.5	190	31	14	255	315	1	25,280

5-25 N · m torque range type added

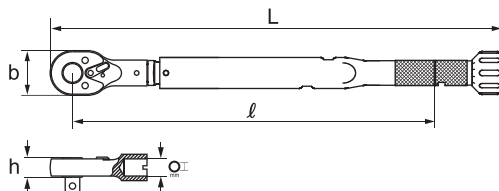



# New item

## LCS Torque Wrench Set, Type Open End Head

**9Pcs.**

Code **LCS1000** Price **¥40,800**

Set Contains

Torque Wrench	LC023N (Torque Range 5 ~ 25N·m)
Open End Head	LCS02- 7, 8, 9, 10, 12, 13, 14, 17

- Weight 1.7kg
- Tool Box 135 × 335 × 42mm

5-25 N · m torque range set released



## LCX Torque Wrench Set, Type Hexagon Head

**7Pcs.**

Code **LCX1000** Price **¥40,300**

Set Contains

Torque Wrench	LC023N (Torque Range 5 ~ 25N·m)
Hexagon Head	LCX02- 2.5, 3, 4, 5, 6, 8

- Weight 1.57kg
- Tool Box 135 × 335 × 42mm

5-25 N · m torque range set released



## LCV Torque Wrench Set, Type Socket

**11Pcs.**

Code **LCV1000** Price **¥35,200**

Set Contains

Torque Wrench	LC023N (Torque Range 5 ~ 25N·m)
Ratchet Head	LQ3045
Socket (12pt.)	VS3- 7, 8, 9, 10, 12, 13, 14, 17
Extention Bar	VE0375 (75mm)

- Weight 1.65kg
- Tool Box 135 × 335 × 42mm

5-25 N · m torque range set released



## VCS3 Crowfoot Wrench Set, Spanner Type

**11Pcs.**

Code **VCS3110** Price **¥22,100**

Set Contains

Crowfoot Wrench	VC3- 8, 10, 12, 13, 14, 16, 17, 19, 21, 22, 24
Holder	275mm

- Weight 380g
- Tool Box 290 × 130 × 30 mm

11-size set added



## VCS4 Crowfoot Wrench Set, Spanner Type

**8Pcs.**

Code **VCS4080** Price **¥39,000**

Set Contains

Crowfoot Wrench	VC4- 17, 19, 22, 24, 27, 30, 32, 36
Holder	275mm

- Weight 1.2kg
- Tool Box 290 × 130 × 30 mm

8-size set added



**New item**

## VCL3 Long Crowfoot Wrench, Spanner Type

Code	mm	B mm	b mm	H mm	L mm	effective length ℓ mm	Weight g		Price ¥
VCL3010	10	22	17	8	64.5	50	55	-	2,390
VCL3012	12	25	17	8	66	50	56.5	-	2,540
VCL3013	13	26	17	8	65.5	50	57.5	-	2,540
VCL3014	14	28	17	8	66	50	58.5	-	2,620
VCL3017	17	32	19	8	67.5	50	67.5	-	2,650
VCL3019	19	38	21	8	68.5	50	81.5	-	2,730

• Nickel Chrome Plating

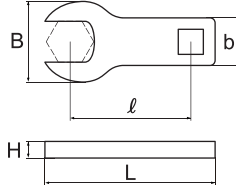

Long type released



**6Pcs.**

Code **VCLS360**

Price **¥16,600**

Set Contains

Crowfoot Wrench VCL3- 10, 12, 13, 14, 17, 19

- Weight 424g
- Storage Box 85 × 235 × 25mm



## VCL4 Long Crowfoot Wrench, Spanner Type

Code	mm	B mm	b mm	H mm	L mm	effective length ℓ mm	Weight g		Price ¥
VCL4019	19	36	22	12	86	65	147	-	4,850
VCL4022	22	42	24	12	87	65	169	-	4,850
VCL4024	24	46	26	12	89.5	65	190	-	5,100
VCL4027	27	50	28	12	91.5	65	207	-	5,400
VCL4030	30	54	28	12	93.5	65	218	-	5,800
VCL4032	32	56	28	12	93	65	218	-	6,000
VCL4036	36	62	30	12	95	65	243	-	6,100

• Nickel Chrome Plating

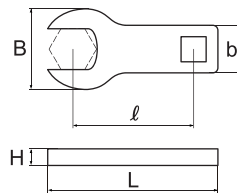

Long type released



**7Pcs.**

Code **VCLS470**

Price **¥39,300**

Set Contains

Crowfoot Wrench VCL4- 19, 22, 24, 27, 30, 32, 36

- Weight 1.5kg
- Storage Box 115 × 440 × 30mm



# Tool Set

## LIGHTTOOL model

TS3100



1/2" Drive  
45 pcs.

Double Open End Spanner  
Offset Wrench  
Ratchet Handle

**LIGHTTOOL®**

Hexagon Key Wrench

**DX2000TOOLS**  
Catcher Ball / Long / Ball Point type

Tool Box

Metallic

## Revowave model

TS3200



1/2" Drive  
44 pcs.

Double Open End Spanner  
Offset Wrench  
Ratchet Handle

**Revowave®**

Hexagon Key Wrench

**DX2000TOOLS**  
Catcher Ball / Long / Ball Point

Socket

Hybrid Socket

Tool Box

Metallic

## Compact Case model

TS4100



1/2" Drive  
36 pcs.

Combination Wrench

**Revowave®**

Ratchet Handle

**LIGHTTOOL®**

Hexagon Key Wrench

**DX2000TOOLS**  
Long / Ball Point type

Tool Box

Metallic

## Double Open End Spanner / Offset Wrench model

TS2000



1/2" Drive  
48 pcs.

Ratchet Handle

**LIGHTTOOL®**

Tool Box

Plastic

## Combination Wrench model

TS2100



1/2" Drive  
46 pcs.

Ratchet Handle

**LIGHTTOOL®**

Tool Box

Plastic





# LIGHTOOL model

## TS3100 Tool Set

**45Pcs.**

Code **TS3100** Price **¥96,600**

**1/2" Drive**

Set Contains	
Double Open End Spanner <b>LIGHTOOL®</b>	LSX-5.5×7, 8×10, 11×13, 12×14, 17×19, 22×24 
Offset Wrench <b>LIGHTOOL®</b>	LOF-10×12, 11×13, 14×17, 19×21, 22×24 
Ratchet Handle <b>LIGHTOOL®</b>	LVR4252
Socket (12point)	VS4-17, 19, 21, 22, 24, 26, 27
Socket (6point)	VJR4-10, 12, 13, 14
Extension Bar	VE0415 (150mm)
Long Ball Point Hexagon Key Wrench Set, With Holding Ball Type (9pcs.)	AQKS910 (AQ- 1.5, 2, 2.5 AQK- 3, 4, 5, 6, 8, 10)
Go-Through Screwdriver (Soft Grip)	SUN FLAG No.888 ⊕No.1×75mm ⊖5.5×75mm ⊕No.2×100mm ⊖6.0×100mm ⊕No.3×150mm ⊖8.0×150mm
Adjustable Wrench	Pro-Auto (300mm)
Combination Plier	PP0200 
Water Pump Plier	PPW0250 
Side Cutting Plier	KEIBA PV-107
Diagonal Cutting Plier	KEIBA N-206
Combination Hammer	OH CH-10 (1pound)

- Weight 11.7kg
- Tool Box 220×415×310mm



### LIGHTOOL - Super Lightweight tools

Highly portable and workable tools are suitable for work in high places or for long periods of use.

It is 20% lighter on the average than our conventional products.

### Catcher Ball - Anti-Drop Hex Keys

A spring suspension and a steel ball implanted by a high-precision processing technology holds the bolt securely.

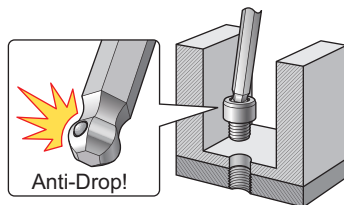

### Metallic tray

The metallic trays are designed to be easy to take tools in and out. Also, they are much more durable than plastic trays and suitable for any types of workplace. Matte-black paint trays go well together with a silver-colored tool case.



TOOL SETS

SPANNERS

STRIKING FACE WRENCHES

HOOK SPANNERS

DX2000 TOOLS  
HEXAGON KEY WRENCHES

HEXAGON KEY WRENCHES

TORQUE WRENCHES

CROWFOOT WRENCHES

SOCKETS

OTHER TOOLS

# Revowave model

## TS3200 Tool Set

**44Pcs.**

Code

**TS3200**

Price

**¥96,100**

Set Contains

Double Open End Spanner <b>Revowave®</b>	SL-5.5×7, 8×10, 11×13, 12×14, 17×19, 22×24	
Offset Wrench <b>Revowave®</b>	OL-10×12, 11×13, 14×17, 19×21, 22×24	
Ratchet Handle <b>Revowave®</b>	VRL4250	
Socket (Hybrid Type)	VF4- 10, 12, 13, 14, 15, 17, 19, 21, 22, 24	
Extension Bar	VE0415 (150mm)	
Long Ball Point Hexagon Key Wrench Set, With Holding Ball Type (9pcs.)	AQKS910 (AQ- 1.5, 2, 2.5 AQK- 3, 4, 5, 6, 8, 10)	
Go-Through Screwdriver (Soft Grip)	SUN FLAG No.888 ⊕No.1×75mm ⊖5.5×75mm ⊕No.2×100mm ⊖6.0×100mm ⊕No.3×150mm ⊖8.0×150mm	
Adjustable Wrench	Pro-Auto (250mm)	
Combination Plier	PP0200	
Water Pump Plier	PPW0250	
Side Cutting Plier	KEIBA PV-107	
Diagonal Cutting Plier	KEIBA N-206	
Combination Hammer	OH CH-10 (1pound)	

- Weight 11.5kg
- Tool Box 220 × 415 × 310mm

### Revowave - High Workability

The curved surface of the neck fits well into hands and increases comfort when working.



Easy-to-grasp-handle

### Catcher Ball - Anti-Drop Hex Keys

A spring suspension and a steel ball implanted by a high-precision processing technology holds the bolt securely.

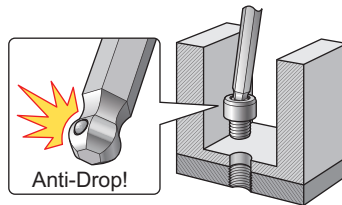

### Hybrid Socket

Due to the unique spline shape interior, a socket is compatible with metric or inch-sized bolts, hexalobe screws, and square bolts.



Unique spline shape

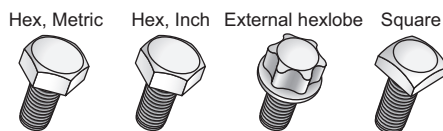

A socket can fit 4 types of bolts

**1/2" Drive**



### Metallic tray

The metallic trays are designed to be easy to take tools in and out. Also, they are much more durable than plastic trays and suitable for any types of workplace. Matte-black paint trays go well together with a silver-colored tool case.



TOOL SETS

SPANNERS

STRIKING FACE WRENCHES

HOOK SPANNERS

DX2000 TOOLS  
HEXAGON KEY WRENCHES

HEXAGON KEY WRENCHES

TORQUE WRENCHES

CROWFOOT WRENCHES

SOCKETS

OTHER TOOLS

## Compact Case model

### TS4100 Tool Set

**36Pcs.**



Code

**TS4100**

Price

**¥68,200**

Set Contains

Combination Wrench <b>Revowave</b>	CL- 8, 10, 12, 13, 14, 17, 19, 22, 24	
Long Ball Point Hexagon Key Wrench Set (8pcs.)	AQS0880 (AQ- 1.5, 2, 2.5, 3, 4, 5, 6, 8)	
Socket (6point)	VJR4- 10, 12, 13, 14	
Socket (12point)	VS4- 17, 19, 21, 22, 24	
Ratchet Handle <b>LIGHTOOL</b>	LVR4252	
Extension Bar	VE0415 (150mm)	
Go-Through Screwdriver (Soft Grip)	SUN FLAG No.888 ⊕No.1 × 75mm    ⊖5.5 × 75mm ⊕No.2 × 100mm   ⊖6.0 × 100mm	
Adjustable Wrench	Pro-Auto (300mm)	
Combination Plier	PP0200	
Side Cutting Plier	CP-175	
Ball Pin Hammer	HP0450 (1pound)	

- Weight 9kg
- Tool Box 230 × 395 × 120mm



### Revowave - Combination Wrench

The curved surface of the neck fits well into hands and increases comfort when working.

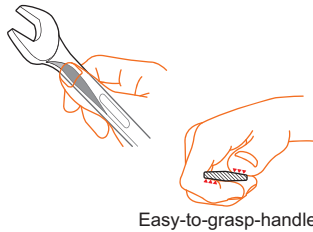
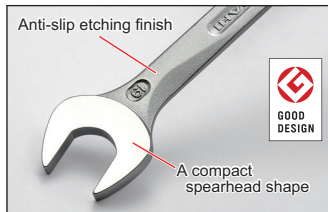

Easy-to-grasp-handle

### LIGHTOOL - Super Lightweight tools

Highly portable and workable tools are suitable for work in high places or for long periods of use.



### Tool Case

As the upper part of the tool case is sliding type, opening and closing can be done easily. It is 120 mm high and compact so it does not take up space when storing and it is convenient to carry.



### Tray for sockets

The metallic trays are designed to be easy to take tools in and out. A tray can store different sizes of sockets, ratchet handles, and extension bars. It is useful for carrying sockets and ratchets to work areas.



TOOL SETS

SPANNERS

STRIKING FACE WRENCHES

HOOK SPANNERS

DX2000 TOOLS

HEXAGON KEY WRENCHES

TORQUE WRENCHES

CROWFOOT WRENCHES

SOCKETS

OTHER TOOLS

## Double Open End Spanner / Offset Wrench model

### TS2000 Tool Set

**48Pcs.**

Code **TS2000** Price **¥76,300**



Set Contains	
Double Open End Spanner	SMS0622 (SM- 5.5 × 7, 8 × 10, 11 × 13, 12 × 14, 17 × 19, 22 × 24)
Offset Wrench	8 × 10, 11 × 13, 12 × 14, 14 × 17, 17 × 19, 22 × 24
Hexagon Key Wrench Set (8pcs.)	AWS0820 (AW- 3, 4, 5, 6, 8, 10, 12, 14)
Socket (12point)	VS4- 10, 11, 12, 13, 14, 17, 19, 21, 22, 24
Plug Socket (12point)	VP0421 (21mm)
Ratchet Handle <b>LIGHTTOOL®</b>	LVR4252
Extension Bar	VE0415 (150mm)
Universal Joint	VU0400
Spinner Handle	VH0430 (300mm)
Cross Bar	VB0425 (250mm)
Go-Through Screwdriver (Plastic Grip)	⊕ No.1 × 75mm    ⊖ 5.5 × 75mm ⊕ No.2 × 100mm    ⊖ 6.0 × 100mm ⊕ No.3 × 150mm
Stubby Screwdriver (Plastic Grip)	Interchangeable (Phillips & Slotted)
Adjustable Wrench	Pro-Auto (250mm)
Combination Plier	PP0200
Side Cutting Plier	CP-175
Diagonal Cutting Plier	CN-160
Needle Nose Plier	RP-150
Ball Pin Hammer	HP0450 (1pound)

- Weight 9.3kg
- Tool Box 260 × 445 × 222mm

### A Wide Range of Sizes and Shapes

Mainly we have a rich variety of frequently used tools centering on double open spanner and double offset wrench.

### Tool Case

It is light and convenient to carry and abs plastic tool case. The upper tray can store the tool properly, it can be removed and carried. The lower space is large capacity and can be store many hand tools.



TOOL SETS

SPANNERS

STRIKING FACE WRENCHES

HOOK SPANNERS

DX2000 TOOLS  
HEXAGON KEY WRENCHES

HEXAGON KEY WRENCHES

TORQUE WRENCHES

CROWFOOT WRENCHES

SOCKETS

OTHER TOOLS

## Combination Wrench model

### TS2100 Tool Set

**46Pcs.**

Code

**TS2100**

Price

**¥76,300**



Set Contains

Combination Wrench	CP- 5.5, 7, 8, 10, 12, 13, 14, 17, 19, 22, 24	
Hexagon Key Wrench Set (9pcs.)	AWS0990 (AW- 1.5, 2, 2.5, 3, 4, 5, 6, 8, 10)	
Socket (12point)	VS4- 10, 12, 13, 14, 17, 19, 21, 22, 24	
Ratchet Handle <b>LIGHTOOL®</b>	LVR4252	
Extension Bar	VE0415 (150mm)	
Universal Joint	VU0400	
Spinner Handle	VH0430 (300mm)	
Cross Bar	VB0425 (250mm)	
Go-Through Screwdriver (Plastic Grip)	⊕ No.1 × 75mm    ⊖ 5.5 × 75mm ⊕ No.2 × 100mm    ⊖ 6.0 × 100mm ⊕ No.3 × 150mm	
Stubby Screwdriver (Plastic Grip)	Interchangeable (Phillips & Slotted)	
Adjustable Wrench	Pro-Auto (250mm)	
Combination Plier	PP0200	
Side Cutting Plier	CP-175	
Diagonal Cutting Plier	CN-160	
Needle Nose Plier	RP-150	
Ball Pin Hammer	HP0450 (1 pound)	

- Weight 8kg
- Tool Box 260 × 445 × 222mm

### A Wide Range of Sizes and Shapes

Mainly we have a rich variety of frequently used tools centering on combination wrench.

### Tool Case

It is light and convenient to carry and abs plastic tool case. The upper tray can store the tool properly, it can be removed and carried. The lower space is large capacity and can be store many hand tools.



TOOL SETS

SPANNERS

STRIKING FACE WRENCHES

HOOK SPANNERS

DX2000 TOOLS  
HEXAGON KEY WRENCHES

HEXAGON KEY WRENCHES

TORQUE WRENCHES



CROWFOOT WRENCHES







SOCKETS

OTHER TOOLS



# Spanners

Single Open End Spanner		
	SS	SSP
Heavy Duty	●	●
 Width across flat		
5.5	●	●
6	●	●
7	●	●
8	●	●
9	●	●
10	●	●
11	●	●
12	●	●
13	●	●
14	●	●
16	●	●
17	●	●
18	●	●
19	●	●
21	●	●
22	●	●
23	●	●
24	●	●
26	●	●
27	●	●
29	●	●
30	●	●
32	●	●
35	●	●
36	●	●
38	●	●
41	●	●
46	●	●
50	●	●
54	●	●
55	●	●
58	●	●
60	●	●
63	●	●
65	●	●
67	●	●
70	●	●
71	●	●
75	●	●
77	●	●
80	●	●
85	●	●
90	●	●
95	●	●
100	●	●
105	●	●
110	●	●
115	●	●
120	●	●
125	●	●
130	●	●
135	●	●
140	●	●
145	●	●
150	●	●
155	●	●
160	●	●
165	●	●
170	●	●
175	●	●
180	●	●
185	●	●
190	●	●
195	●	●
200	●	●

Double Open End Spanner						
	SW	SNT	SM	SMC	LSX	SL
Heavy Duty	●					
Thin Type		●				
LIGHTTOOL					●	
Revovave						●
 Width across flat						
3.2 x 4				●		
4 x 5				●		
5.5 x 7	●			●	●	●
6 x 7	●		●		●	●
6 x 8	●					
7 x 8	●		●			
8 x 9	●	●	●			●
8 x 10	●		●		●	●
9 x 10	●					
10 x 12	●	●	●		●	●
10 x 13	●		●			●
10 x 14	●					
11 x 13	●	●	●		●	●
12 x 14	●		●		●	●
13 x 17	●		●		●	●
14 x 17	●	●	●		●	●
17 x 19	●		●		●	●
17 x 21	●					
19 x 21	●	●	●		●	●
19 x 22	●					
19 x 24	●					
21 x 23	●		●			
21 x 26	●					
22 x 23	●	●				
22 x 24	●		●		●	●
23 x 26	●					
24 x 27	●	●				
24 x 30	●					
26 x 29	●					
26 x 32	●					
27 x 30	●					
29 x 32	●					
30 x 32	●	●				
32 x 35	●					
32 x 36	●					
35 x 41	●					
36 x 41	●					
41 x 46	●					
41 x 50	●					
46 x 50	●					
50 x 54	●					
50 x 55	●					
50 x 58	●					
50 x 60	●					
54 x 58	●					
55 x 60	●					

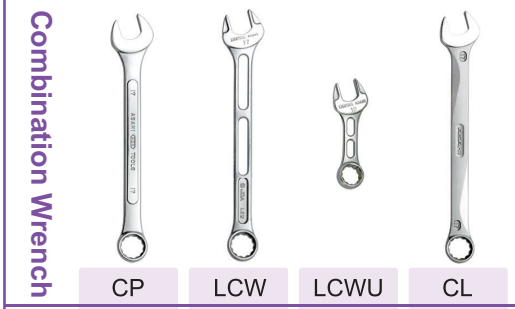

Combination Wrench	CP	LCW	LCWU	CL
LIGHTTOOL		●	●	
Revolwave				●
mm Width across flat				
5.5	●	●	●	●
6	●		●	●
7	●	●	●	●
8	●	●	●	●
9	●		●	●
10	●	●	●	●
11	●		●	●
12	●	●	●	●
13	●	●	●	●
14	●	●	●	●
15	●	●		●
16	●	●		●
17	●	●	●	●
18	●		●	●
19	●	●		●
20	●			●
21	●	●		●
22	●	●		●
23	●			●
24	●	●		●
25	●			●
26	●			●
27	●	●		●
28	●			●
29	●			●
30	●	●		●
31	●			●
32	●	●		●
35	●			●
36	●			●
38	●			●
41	●			●
46	●			●
50	●			●
54	●			●
55	●			●
58	●			●
60	●			●

**Inch**

CPX	
inch Width across flat	
1/4	●
5/16	●
3/8	●
7/16	●
1/2	●
9/16	●
5/8	●
11/16	●
3/4	●
13/16	●
7/8	●
15/16	●
1	●
1-1/16	●
1-1/8	●
1-1/4	●

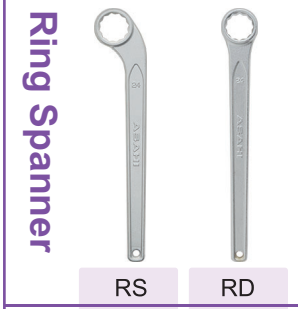

Ring Spanner	RS	RD
Deep Type		●
mm Width across flat		
10	●	
11	●	
12	●	
13	●	
14	●	
17	●	●
19	●	●
21	●	●
22	●	●
23	●	
24	●	●
26	●	
27	●	
29	●	
30	●	
32	●	
35	●	
36	●	
38	●	
41	●	
46	●	
50	●	
54	●	
55	●	
58	●	
60	●	
63	●	
65	●	
67	●	
70	●	
71	●	
75	●	
77	●	
80	●	
85	●	
90	●	
95	●	
100	●	
105	●	
110	●	
115	●	
120	●	
125	●	
130	●	
135	●	
140	●	
145	●	
150	●	
155	●	
160	●	
165	●	
170	●	
175	●	
180	●	
185	●	
190	●	
195	●	
200	●	

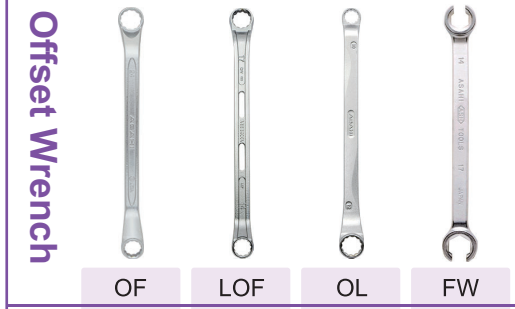

Offset Wrench	OF	LOF	OL	FW
LIGHTTOOL		●		
Revolwave			●	
Flare Nut				●
mm Width across flat				
8 × 9	●			
8 × 10	●	●	●	●
10 × 11	●			●
10 × 12	●	●	●	●
10 × 13	●			
11 × 13	●	●	●	●
12 × 14	●	●	●	●
13 × 15	●	●		
13 × 17	●			
14 × 17	●	●	●	●
16 × 18		●		
17 × 19	●	●	●	
17 × 21	●			
19 × 21	●	●	●	●
19 × 22	●			
19 × 24	●			
21 × 23	●			
21 × 26	●			
22 × 24	●	●	●	
23 × 26	●			
24 × 27	●			
24 × 30	●			
26 × 29	●			
26 × 32	●			
27 × 30	●			
29 × 32	●			
30 × 32	●			
32 × 35	●			
32 × 36	●			
35 × 41	●			
36 × 41	●			

## SS Single Open End Spanner, Metric

Code	mm	C mm	T mm	L mm	Weight g	Box	Price ¥
SS0005	5.5	17	3.2	82	10	10	600
SS0006	6	17	3.2	82	10	10	600
SS0007	7	20	4	92	20	10	600
SS0008	8	20	4	92	20	10	600
SS0009	9	24	4.5	105	30	10	750
SS0010	10	24	4.5	105	30	10	650
SS0011	11	29	5.5	122	40	10	750
SS0012	12	29	5.5	122	50	10	660
SS0013	13	33	6.2	135	50	10	660
SS0014	14	33	6.2	135	60	10	700
NEW SS0016	16	39	7.7	165	100	10	930
SS0017	17	39	7.7	165	100	10	750
NEW SS0018	18	43	8.2	177	120	10	960
SS0019	19	43	8.2	177	120	10	810
SS0021	21	49	9.5	200	160	10	960
SS0022	22	49	9.5	200	150	10	1,090
SS0023	23	53	10.5	220	220	10	1,490
SS0024	24	53	10.5	220	220	10	1,260
SS0026	26	59	11.5	245	290	10	1,330
SS0027	27	59	11.5	245	300	10	1,460
SS0029	29	66	12.5	275	440	10	2,050
SS0030	30	68	12.5	275	440	10	1,720
SS0032	32	68	12.5	275	430	10	1,860
SS0035	35	80	14.5	315	520	5	2,940
SS0036	36	80	14.5	315	600	5	2,750
SS0038	38	80	14.5	315	610	5	3,840
SS0041	41	90	16	360	850	5	3,450
SS0046	46	102	18.5	410	1,340	5	4,730
SS0050	50	102	18.5	410	1,340	5	6,000
SS0054	54	117	20	470	1,790	2	10,900
SS0055	55	117	20	470	1,840	2	10,000
SS0058	58	117	20	470	1,740	2	13,500
SS0060	60	130	22	530	2,510	2	15,600
SS0063	63	130	22	530	2,500	2	18,200
SS0065	65	130	22	530	2,480	2	20,300
SS0067	67	143	24	575	3,070	2	24,500
SS0070	70	143	24	575	3,230	2	27,300
SS0071	71	143	24	575	3,020	2	29,960
SS0075	75	161	24	645	3,950	2	31,500
SS0077	77	161	24	645	3,950	2	38,900
SS0080	80	161	24	645	3,950	2	38,900
SS0085	85	178	29	715	7,400	-	42,300
SS0090	90	178	29	715	7,400	-	50,000
SS0095	95	195	32	770	10,500	-	52,800
SS0100	100	195	32	770	10,500	-	65,490



Thicker bolt contact surfaces enable work at higher loads—it's over 1.5 times stronger than our SN spanner.

The handle is designed for easy gripping, and the surface is finished in cathodic electrodeposition coating for outstanding rust prevention.

This is a strong tool that can be used in harsh environments with peace of mind.

Code	mm	C <sub>1</sub> mm	T mm	L mm	Weight g	Box	Price ¥
SS0105	105	215	35	825	11,600	-	81,400
SS0110	110	215	35	825	11,600	-	94,800
SS0115	115	235	38	870	16,300	-	101,400
SS0120	120	235	38	870	16,300	-	117,400
SS0125	125	250	40	900	-	-	-
SS0130	130	250	40	900	-	-	-
SS0135	135	270	40	925	-	-	-
SS0140	140	270	40	925	-	-	-
SS0145	145	290	45	950	-	-	-
SS0150	150	290	45	950	-	-	-
SS0155	155	310	45	975	-	-	-
SS0160	160	310	45	975	-	-	-
SS0165	165	330	50	1,000	-	-	-
SS0170	170	330	50	1,000	-	-	-
SS0175	175	350	50	1,025	-	-	-
SS0180	180	350	50	1,025	-	-	-
SS0185	185	370	55	1,050	-	-	-
SS0190	190	370	55	1,050	-	-	-
SS0195	195	390	55	1,075	-	-	-
SS0200	200	390	55	1,075	-	-	-

- Cathodic Electrodeposition
- Special Order (0125 ~ )
- Heavy Duty

H  JQA ( ~ SS0080)

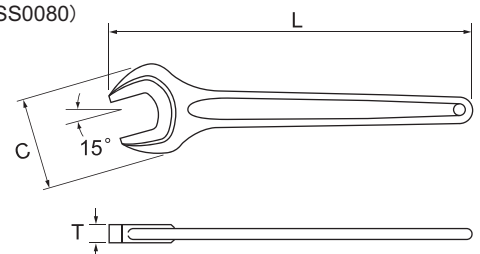

## SSP Single Open End Spanner, Metric

Code	mm	C mm	T mm	L mm	Weight g	Box	Price ¥
SSP0005	5.5	17	3.2	82	10	10	730
SSP0006	6	17	3.2	82	10	10	730
SSP0007	7	20	4	92	20	10	730
SSP0008	8	20	4	92	20	10	730
SSP0009	9	24	4.5	105	30	10	830
SSP0010	10	24	4.5	105	30	10	780
SSP0011	11	29	5.5	122	40	10	830
SSP0012	12	29	5.5	122	50	10	790
SSP0013	13	33	6.2	135	50	10	790
SSP0014	14	33	6.2	135	60	10	840
SSP0017	17	39	7.7	165	100	10	910
SSP0019	19	43	8.2	177	120	10	980
SSP0021	21	49	9.5	200	160	10	1,340
SSP0022	22	49	9.5	200	150	10	1,520
SSP0023	23	53	10.5	220	220	10	1,760
SSP0024	24	53	10.5	220	220	10	1,700
SSP0026	26	59	11.5	245	290	10	1,730
SSP0027	27	59	11.5	245	300	10	1,890
SSP0029	29	66	12.5	275	440	10	2,450
SSP0030	30	68	12.5	275	440	10	2,340
SSP0032	32	68	12.5	275	430	10	2,340
SSP0035	35	80	14.5	315	520	5	3,530
SSP0036	36	80	14.5	315	600	5	3,460
SSP0038	38	80	14.5	315	610	5	4,600
SSP0041	41	90	16	360	850	5	4,300
SSP0046	46	102	18.5	410	1,340	5	5,700
SSP0050	50	102	18.5	410	1,340	5	7,300
SSP0055	55	117	20	470	1,840	2	11,600
SSP0060	60	130	22	530	2,510	2	18,700
SSP0065	65	130	22	530	2,480	2	24,000
SSP0070	70	143	24	575	3,230	2	32,100
SSP0075	75	161	24	645	3,950	2	35,000

- Heavy Duty
- Nickel Chrome Plating

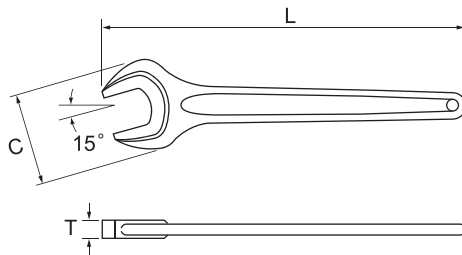

NEW



Thicker bolt contact surfaces enable work at higher loads—it's over 1.5 times stronger than our SN spanner.  
The surface is finished in nickel-chrome plating for an attractive finish.  
This is a strong tool that can be used in harsh environments with peace of mind.

TOOL SETS

SPANNERS

STRIKING FACE WRENCHES

HOOK SPANNERS

DX2000 TOOLS  
HEXAGON KEY WRENCHES

HEXAGON KEY WRENCHES

TORQUE WRENCHES

CROWFOOT WRENCHES

SOCKETS

OTHER TOOLS

## SW Double Open End Spanner, Metric

Code	mm	C <sub>1</sub> mm	C <sub>2</sub> mm	T mm	L mm	Weight g		Price ¥
SW0507	5.5×7	16.5	19.5	3.7	100	20	10	650
SW0607	6×7	16.5	19.5	3.7	100	20	10	650
SW0608	6×8	17.5	21.5	4.2	105	30	10	650
SW0708	7×8	17.5	21.5	4.2	105	30	10	650
SW0809	8×9	21.5	23.5	4.2	115	30	10	730
SW0810	8×10	21.5	23.5	4.2	115	30	10	700
SW0910	9×10	21.5	23.5	4.2	115	40	10	770
SW1012	10×12	25.5	28.5	5.2	130	50	10	700
SW1013	10×13	25.5	32.5	6.2	140	60	10	710
SW1014	10×14	25.5	32.5	6.2	140	60	10	870
SW1113	11×13	29	33	6.2	140	60	10	730
SW1214	12×14	29	33	6.2	140	70	10	730
SW1317	13×17	33	39	7.7	165	100	10	750
SW1417	14×17	33	39	7.7	165	120	10	750
SW1719	17×19	39	43	8.2	177	160	10	860
SW1721	17×21	41	49	9.5	200	200	10	1,020
SW1921	19×21	41	49	9.5	200	200	10	1,070
SW1922	19×22	41	49	9.5	200	200	10	1,090
SW1924	19×24	44	55	10.5	220	260	10	1,230
SW2123	21×23	49	53	10.5	220	260	10	1,590
SW2126	21×26	50	59	11.5	230	310	10	1,320
SW2224	22×24	49	53	10.5	220	270	10	1,500
SW2326	23×26	50	59	11.5	230	310	10	1,740
SW2427	24×27	53	62	11.5	257	440	10	1,860
SW2430	24×30	53	62	11.5	257	440	10	1,890
SW2629	26×29	59	68	12.5	270	540	10	2,450
SW2632	26×32	59	68	12.5	270	480	10	2,160
SW2730	27×30	59	68	12.5	270	520	10	2,300
SW2932	29×32	65	72	13	280	550	10	3,240
SW3032	30×32	65	72	13	280	460	10	2,860
SW3235	32×35	72	79	14.5	310	810	5	3,480
SW3236	32×36	72	79	14.5	310	800	5	3,480
SW3541	35×41	79	90	16	350	1,190	5	4,150
SW3641	36×41	79	90	16	350	1,110	5	5,700
SW4146	41×46	90	101	18	410	1,480	2	7,400
SW4150	41×50	90	101	18	410	1,480	2	10,350
SW4650	46×50	101	109	19	430	1,840	2	9,800
SW5054	50×54	101	109	19	430	1,750	2	18,400
SW5055	50×55	101	109	19	430	1,860	2	15,100
SW5058	50×58	109	126	21	475	2,500	2	21,200
SW5060	50×60	109	126	21	475	2,500	2	21,200
SW5458	54×58	109	126	21	475	2,500	2	21,200
SW5560	55×60	109	126	21	475	2,500	2	21,200

- Cathodic Electrodeposition
- Heavy Duty

H  JQA (0507 ~ 2430, 2632 ~ 4600)

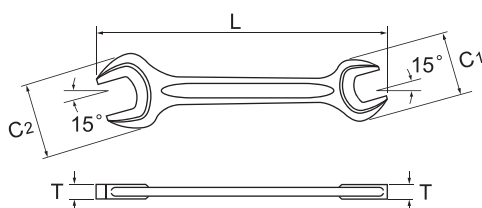

Thicker bolt contact surfaces enable work at higher loads—it's over 1.5 times stronger than our SN spanner.

The handle is designed for easy gripping, and the surface is finished in cationic electrodeposition coating for outstanding rust prevention.

This is a strong tool that can be used in harsh environments with peace of mind.

# SNT Thin Spanner

Code	mm	C <sub>1</sub> mm	C <sub>2</sub> mm	T mm	L mm	Weight g	Box	Price ¥
SNT0809	8×9	19	21	3.2	106	20	10	480
SNT1012	10×12	23	26	3.2	126	30	10	480
SNT1113	11×13	26	30	4	136	50	10	540
SNT1417	14×17	30	33	4	148	60	10	590
SNT1921	19×21	40	45	4	192	100	10	880
SNT2223	22×23	43	49	4.5	205	110	10	1,180
SNT2427	24×27	50	56	4.5	235	182	10	1,860
SNT3032	30×32	63	66	4.5	275	244	10	2,550

• Nickel Chrome Plating

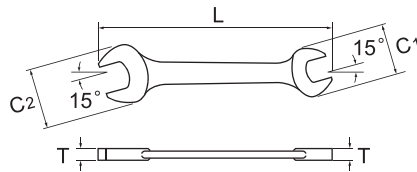

Suitable for use in places where ordinary spanners cannot fit, due to its significantly thinner profile.

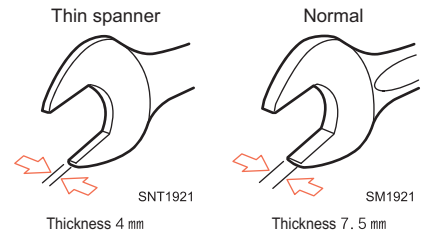

<b>5Pcs.</b>	Code	<b>SNT0550</b>	Price	<b>¥2,790</b>
Set Contains				
Double Open End Spanner	SNT- 8×9, 10×12, 11×13, 14×17, 19×21			

- Weight 290g
- Blister pack 270 × 70 × 30mm
- Metal Holder



SNT0550

<b>8Pcs.</b>	Code	<b>SNT0800</b>	Price	<b>¥8,200</b>
Set Contains				
Double Open End Spanner	SNT- 8×9, 10×12, 11×13, 14×17, 19×21, 22×23, 24×27, 30×32			

- Weight 850g
- Casing 306 × 65 × 36mm

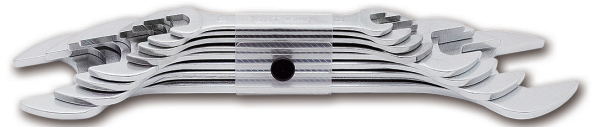

SNT0800

TOOL SETS

SPANNERS

STRIKING FACE WRENCHES

HOOK SPANNERS

HEXAGON KEY WRENCHES

HEXAGON KEY WRENCHES

TORQUE WRENCHES

CROWFOOT WRENCHES

SOCKETS

OTHER TOOLS

## SM Double Open End Spanner, Metric

Code	mm	C <sub>1</sub> mm	C <sub>2</sub> mm	T mm	L mm	Weight g		Price ¥
SM0507	5.5×7	16	19	3.5	102	20	10	520
SM0607	6×7	16	19	3.5	102	20	10	520
SM0708	7×8	17	21	4	105	30	10	540
SM0809	8×9	19	21.5	4	115	30	10	540
SM0810	8×10	19	21.5	4	115	30	10	590
SM1012	10×12	21.5	26	4.5	125	45	10	590
SM1013	10×13	23	27.5	5	130	45	10	650
SM1113	11×13	23	27.5	5	130	50	10	650
SM1214	12×14	25	31.5	5.5	140	70	10	650
SM1317	13×17	32	37.5	6	160	100	10	830
SM1417	14×17	32	37.5	6	160	100	10	830
SM1719	17×19	37.5	41.5	6.5	180	135	10	1,010
SM1921	19×21	40	46	7.5	195	150	5	1,240
SM2123	21×23	44	48.5	8	205	215	5	1,290
SM2224	22×24	44	50	8.5	215	220	5	1,430

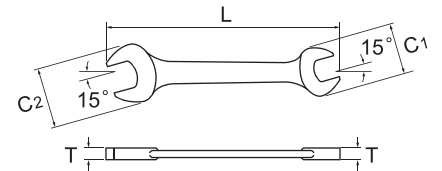

• Nickel Chrome Plating  JQA

**6Pcs.**

Code **SMS0600**

Price **¥4,130**

Set Contains

Double Open End Spanner SM- 5.5×7, 8×10, 11×13, 12×14, 13×17, 17×19

- Weight 432g
- Metal Holder



SMS0600

**6Pcs.**

Code **SMS0610**

Price **¥4,390**

Set Contains

Double Open End Spanner SM- 8×9, 10×12, 12×14, 14×17, 17×19, 21×23

- Weight 610g
- Metal Holder
- Blister pack 270×70×55mm

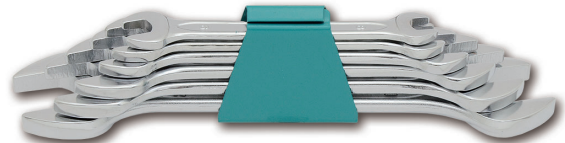

SMS0610

**6Pcs.**

Code **SMS0620**

Price **¥4,390**

Set Contains

Double Open End Spanner SM- 8×10, 11×13, 12×14, 14×17, 17×19, 22×24

- Weight 624g
- Metal Holder
- Blister pack 270×70×55mm

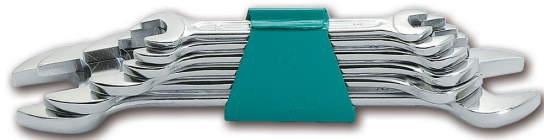

SMS0620

**6Pcs.**

Code **SMS0622**

Price **¥4,390**

Set Contains

Double Open End Spanner SM- 5.5×7, 8×10, 11×13, 12×14, 17×19, 22×24

- Weight 544g
- Metal Holder
- Blister pack 270×70×55mm

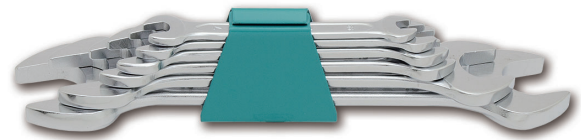

SMS0622

**8Pcs.**

Code **SMS0800**

Price **¥5,900**

Set Contains

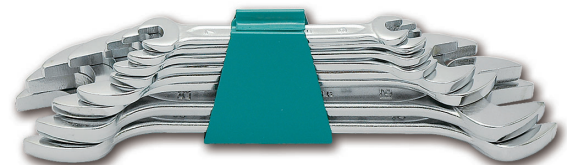

Double Open End Spanner SM- 6×7, 8×9, 10×12, 11×13, 14×17, 17×19, 21×23, 22×24

- Weight 827g
- Metal Holder
- Storage Box 220×60×55mm



SMS0800

## SMC Double Open End Spanner, Metric

Code	 mm	C <sub>1</sub> mm	C <sub>2</sub> mm	T mm	L mm	Weight g		Price ¥
SMC0304	3.2×4	10	11	3	82	10	10	510
SMC0405	4×5	12.6	13.5	3.2	91	13	10	510
SMC0507	5.5×7	16.5	19.5	3.7	100	20	10	680

• Nickel Chrome Plating

H  JGA (5.5 × 7mm)

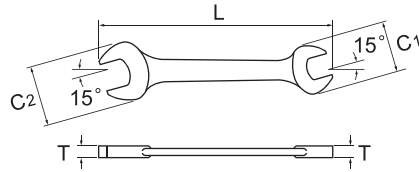

**3Pcs.**

Code **SMCS300**

Price **¥1,920**

Set Contains

Double Open End Spanner SMC- 3.2×4, 4×5, 5.5×7

• Weight 60g

• Tool Roll 180 × 100mm



TOOL SETS

SPANNERS

STRIKING-FACE WRENCHES

HOOK SPANNERS

DX2000 TOOLS  
HEXAGON KEY WRENCHES

HEXAGON KEY WRENCHES

TORQUE WRENCHES

CROWFOOT WRENCHES

SOCKETS

OTHER TOOLS



## LSX Double Open End Spanner, Metric

Code	mm	C <sub>1</sub> mm	C <sub>2</sub> mm	T mm	L mm	Weight g	Box	Price ¥
LSX0507	5.5×7	12.7	15.5	2.9	102	10	10	710
LSX0607	6×7	12.7	15.5	2.9	102	9	10	710
LSX0810	8×10	17.5	21.5	4.2	115	19	10	740
LSX1012	10×12	21.5	26.0	5.0	125	33	10	770
LSX1113	11×13	23.5	28.0	5.4	130	40	10	1,000
LSX1214	12×14	26.0	29.5	5.8	140	47	10	1,000
LSX1317	13×17	28.5	36.0	6.7	160	75	10	1,130
LSX1417	14×17	28.5	36.0	6.7	160	74	10	1,130
LSX1719	17×19	36.0	40.0	7.0	177	105	10	1,360
LSX1921	19×21	40.0	44.5	7.5	195	150	5	1,460
LSX2224	22×24	46.5	50.5	8.0	215	180	5	1,920

• Nickel Chrome Plating

S **JIS** JQA

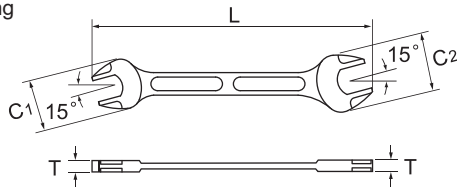

## LIGHTOOL®



LIGHTOOL is both portable and comfortable to use—an effective choice for working at high elevations or for long hours.

Achieved through painstaking testing, its optimized design and advanced forging technology ensure robust strength, which is the true hurdle of weight reduction, and its strength exceeds JIS standards.

**6Pcs.**

Code

**LSXS6**

Price

**¥6,700**

Set Contains

Double Open End Spanner LSX-5.5×7, 8×10, 11×13, 12×14, 17×19, 22×24

• Weight 505g

• Tool Roll 280×285mm



TOOL SETS

SPANNERS

STRIKING FACE WRENCHES

HOOK SPANNERS

DX2000 TOOLS  
HEXAGON KEY WRENCHES

HEXAGON KEY WRENCHES

TORQUE WRENCHES

CROWFOOT WRENCHES

SOCKETS

OTHER TOOLS

## SL Double Open End Spanner, Metric

Code	mm	C <sub>1</sub> mm	C <sub>2</sub> mm	T mm	L mm	Weight g	Box	Price ¥
SL0507	5.5×7	12.7	15.5	2.9	102	12	10	690
SL0607	6×7	13.7	15.5	2.9	102	12	10	690
SL0809	8×9	17.5	19.5	4.0	111	25	10	720
SL0810	8×10	17.5	21.5	4.2	122	28	10	730
SL1012	10×12	21.5	25.5	5.2	133	43	10	760
SL1013	10×13	21.5	28.0	5.6	136	50	10	890
SL1113	11×13	23.5	28.0	6.0	138	56	10	990
SL1214	12×14	25.5	29.5	6.5	143	68	10	990
SL1317	13×17	28.0	36.0	6.6	168	90	10	1,070
SL1417	14×17	29.5	36.0	6.7	170	100	10	1,110
SL1719	17×19	36.0	40.0	7.0	185	130	10	1,340
SL1921	19×21	40.0	44.5	7.6	205	170	5	1,450
SL2224	22×24	46.5	50.5	8.5	225	240	5	1,830

- Decorative Chromium Plating

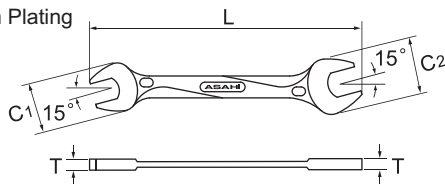

Revovave®



Revovave features an innovative design, never seen before. The curved surface of its distinctive neck fits the worker's hand perfectly, providing excellent workability.

**6Pcs.**

Code **SLAS6**

Price **¥6,700**

Set Contains

Double Open End Spanner SL- 5.5×7, 8×10, 11×13, 12×14, 17×19, 22×24

- Weight 560g
- Storage Box 125 × 240 × 50mm
- Plastic Holder (TFSLH01)



SLAS6

**6Pcs.**

Code **SLAS62**

Price **¥7,200**

Set Contains

Double Open End Spanner SL- 8×10, 11×13, 12×14, 14×17, 17×19, 22×24

- Weight 650g
- Storage Box 125 × 240 × 50mm
- Plastic Holder (TFSLH01)



SLAS62

Code	Weight g	Price ¥
TFSLH01	35	610

- for SLAS6 and SLAS62
- Plastic



TFSLH01

## CP Combination Wrench, Metric

Code	mm	C mm	D mm	T <sub>1</sub> mm	T <sub>2</sub> mm	L mm	Weight g	Box	Price ¥
CP0005	5.5	13.5	10	3	5	94	14	10	700
CP0006	6	15.5	10.5	3.5	5	99	14	10	700
CP0007	7	19.5	13	4	6.5	105	21	10	700
CP0008	8	19.5	13	4	6.5	105	20	10	700
CP0009	9	20	14	4.5	6.5	110	25	10	720
CP0010	10	22	15.3	4.7	6.5	118	31	10	720
CP0011	11	24	17.5	5.2	7	134	43	10	820
CP0012	12	25.5	18.5	5.5	7.5	140	48	10	870
CP0013	13	26.8	20	6.2	8	149	65	10	920
CP0014	14	30.8	22	6.2	8.5	170	84	10	970
CP0015	15	32	23	6.5	9	180	105	10	1,160
CP0016	16	34.3	24.5	7	9	190	114	10	1,190
CP0017	17	37	26	7.7	10.5	215	160	10	1,190
CP0018	18	39.5	28.5	8.2	11.5	235	190	10	1,350
CP0019	19	39.5	28.5	8.2	11.5	235	182	10	1,350
CP0020	20	45	31	8.5	12	265	265	10	1,730
CP0021	21	45	31	8.5	12	265	246	10	1,730
CP0022	22	46	32.5	9.5	12.5	280	289	10	1,850
CP0023	23	49.5	35	10	13.5	310	390	10	2,180
CP0024	24	49.5	35	10	13.5	310	370	10	2,180
CP0025	25	52	37.5	10.5	14.5	330	405	10	2,670
CP0026	26	52	37.5	10.5	14.5	330	400	10	2,670
CP0027	27	58	39.5	10.5	16	360	520	5	2,920
CP0028	28	59.5	43	11.5	17	387	645	5	3,890
CP0029	29	59.5	43	11.5	17	387	600	5	4,840
CP0030	30	59.5	43	11.5	17	387	615	5	3,890
CP0031	31	66	47.5	12.5	19	420	850	5	6,960
CP0032	32	66	47.5	12.5	19	420	846	5	4,320
CP0035	35	73	53	12.5	19.5	465	1,060	5	7,350
CP0036	36	73	53	12.5	19.5	465	1,050	5	7,600
CP0038	38	76.5	54.5	13.5	21	490	1,120	5	10,200
CP0041	41	81.5	61	14.5	22	520	1,600	5	10,200
CP0046	46	91	69.5	16	24	580	2,150	5	12,800
CP0050	50	91	69.5	16	24	580	2,100	5	15,900
CP0054	54	104	80	18	28	635	3,000	2	30,220
CP0055	55	104	80	18	28	635	2,950	2	20,290
CP0058	58	115	90	20	31	710	4,210	2	35,620
CP0060	60	115	90	20	31	710	4,160	2	24,090

• Nickel Chrome Plating

**JIS JQA** (Except for 0020, 0025, 0028, 0060)

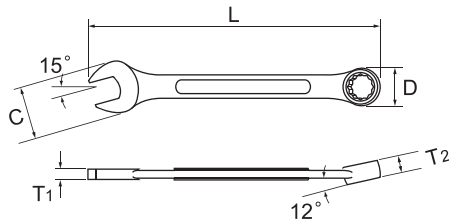

TOOL SETS

SPANNERS

STRIKING FACE WRENCHES

HOOK SPANNERS

DX2000 TOOLS  
HEXAGON KEY WRENCHES

HEXAGON KEY WRENCHES

TORQUE WRENCHES

GROWFOOT WRENCHES

SOCKETS

OTHER TOOLS

## CP Combination Wrench, Metric

**10Pcs.**

Code **CPS1010**

Price **¥13,200**

Set Contains

Combination Wrench CP-8, 10, 12, 13, 14, 17, 19, 21, 22, 24

- Weight 1800g
- Tool Roll 420 × 455mm



CPS1010

**14Pcs.**

Code **CPS1410**

Price **¥24,700**

Set Contains

Combination Wrench CP-5.5, 7, 8, 10, 12, 13, 14, 17, 19, 22, 24, 27, 30, 32

- Weight 3500g
- Tool Roll 525 × 660mm

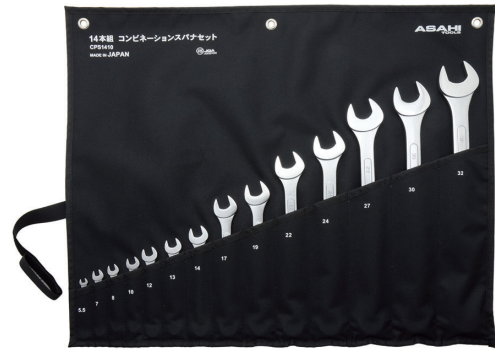

CPS1410

TOOL SETS

SPANNERS

STRIKING FACE WRENCHES

HOOK SPANNERS

DX2000 TOOLS  
HEXAGON KEY WRENCHES

HEXAGON KEY WRENCHES

TORQUE WRENCHES

CROWFOOT WRENCHES

SOCKETS

OTHER TOOLS

## CPX Combination Wrench, Inches

Code	inch	C mm	D mm	T <sub>1</sub> mm	T <sub>2</sub> mm	L mm	Weight g	Price ¥
CPX0104	1/4	15.5	10.5	3.5	5	99	15	1,010
CPX0516	5/16	19.5	13	4	6.5	105	20	1,010
CPX0308	3/8	22	15.3	4.7	6.5	118	30	1,110
CPX0716	7/16	24	17.5	5.2	7	134	40	1,210
CPX0102	1/2	26.8	20	6.2	8	149	60	1,350
CPX0916	9/16	30.8	22	6.2	8.5	170	100	1,470
CPX0508	5/8	34.3	24.5	7	9	190	120	1,670
CPX1116	11/16	37	26	7.7	10.5	215	150	1,810
CPX0304	3/4	39.5	28.5	8.2	11.5	235	200	2,020
CPX1316	13/16	45	31	8.5	12	265	280	2,450
CPX0708	7/8	46	32.5	9.5	12.5	280	300	2,730
CPX1516	15/16	49.5	35	10	13.5	310	400	3,000
CPX0101	1	52	37.5	10.5	14.5	330	430	3,840
CPX1716	1-1/16	58	39.5	11	16	360	530	4,760
CPX0908	1-1/8	60	44	12	17	387	700	5,300
CPX0504	1-1/4	66	48	12.5	19	420	830	6,700

• Nickel Chrome Plating

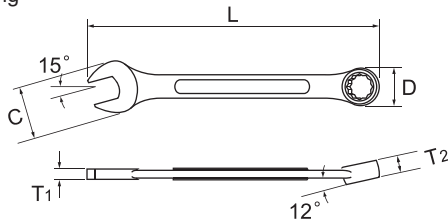

inch



TOOL SETS  
SPANNERS  
STRIKING FACE WRENCHES  
HOOK SPANNERS  
DX2000 TOOLS  
HEXAGON KEY WRENCHES  
HEXAGON KEY WRENCHES  
TORQUE WRENCHES  
CROWFOOT WRENCHES  
SOCKETS  
OTHER TOOLS

**10Pcs.**

Code **CPXS101** Price **¥19,200**

Set Contains

Combination Wrench CPX-3/8, 7/16, 1/2, 9/16, 5/8, 11/16, 3/4, 13/16, 7/8, 15/16

- Weight 1700g
- Tool Roll 380 × 440mm

inch



CPXS101

**14Pcs.**

Code **CPXS141** Price **¥40,300**

Set Contains

Combination Wrench CPX-3/8, 7/16, 1/2, 9/16, 5/8, 11/16, 3/4, 13/16, 7/8, 15/16, 1, 1-1/16, 1-1/8, 1-1/4

- Weight 4200g
- Tool Roll 450 × 640mm

inch



CPXS141

## LCW Combination Wrench, Metric

Code	mm	C mm	D mm	T <sub>1</sub> mm	T <sub>2</sub> mm	L mm	Weight g	Box	Price ¥
LCW0005	5.5	12.7	10.5	2.9	5.0	100	11	10	1,010
LCW0007	7	17.5	12.7	3.5	5.7	105	14	10	1,010
LCW0008	8	17.5	12.7	3.5	5.7	105	13	10	1,010
LCW0010	10	21.5	15.3	4.2	6.5	119	21	10	1,110
LCW0012	12	26.0	18.7	5.0	7.5	141	38	10	1,160
LCW0013	13	28.0	20.0	5.4	8.0	151	45	10	1,280
LCW0014	14	29.5	22.0	5.8	8.5	171	60	10	1,280
LCW0015	15	34.5	23.7	6.0	9.5	191	83	10	1,500
LCW0016	16	34.5	23.7	6.0	9.5	191	80	10	1,500
LCW0017	17	36.0	26.5	6.5	10.5	216	100	10	1,590
LCW0019	19	40.0	28.5	7.0	11.5	235	135	10	1,950
LCW0021	21	46.5	32.0	7.5	12.0	255	200	5	2,620
LCW0022	22	46.5	32.0	7.5	12.0	255	195	5	2,620
LCW0024	24	50.5	34.0	8.0	13.0	280	220	5	3,100
LCW0027	27	56	39.5	10.5	16	340	380	5	4,520
LCW0030	30	62	43	11	18	370	450	5	5,700
LCW0032	32	65.5	47	11.5	18.5	400	600	5	6,600

• Nickel Chrome Plating

JIS JGA

PAT.

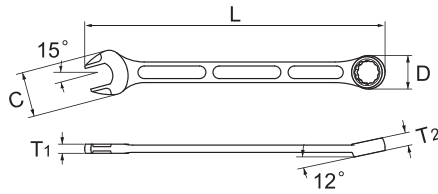

## LIGHTOOL®



12point



LIGHTOOL is both portable and comfortable to use—an effective choice for working at high elevations or for long hours.

Achieved through painstaking testing, its optimized design and advanced forging technology ensure robust strength, which is the true hurdle of weight reduction, and its strength exceeds JIS standards.

**6Pcs.**

Code

**LCWS6**

Price

**¥8,000**

Set Contains

Combination Wrench

LCW-10, 12, 13, 14, 17, 19

• Weight 490g

• Tool Roll 298 × 236mm



TOOL SETS

SPANNERS

STRIKING FACE WRENCHES

HOOK SPANNERS

DX2000 TOOLS  
HEXAGON KEY WRENCHES

HEXAGON KEY WRENCHES

TORQUE WRENCHES

CROWFOOT WRENCHES

SOCKETS

OTHER TOOLS

## LCWU Combination Wrench, Metric

Code	mm	C mm	D mm	T <sub>1</sub> mm	T <sub>2</sub> mm	L mm	Weight g		Price ¥
LCWU005	5.5	13.5	11	2.9	5.1	48	6.7	-	940
LCWU006	6	13.5	11	2.9	5.1	48	6.4	-	940
LCWU007	7	18	13	3.5	5.7	60	11	-	960
LCWU008	8	18	13	3.5	5.7	60	10	-	1,070
LCWU010	10	21	15.3	4.2	6.5	68	15	-	1,150
LCWU012	12	24	19	5.0	7.5	76	25	-	1,220
LCWU013	13	28	20	5.4	8	87	33	-	1,350
LCWU014	14	29.5	22	5.8	8.5	95	44	-	1,390
LCWU017	17	36	26.5	6.5	10.5	115	71	-	1,710

• Nickel Chrome Plating

(PAT.)

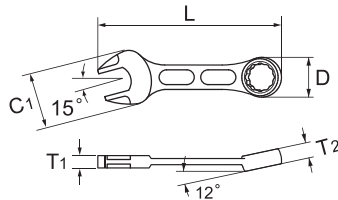

## LIGHTOOL®



To the distinctive light weight, functional form, and high workability of LIGHTOOL, it adds portability. It's easy to carry around, and suited for use as a key holder or strap.

**3Pcs.**

Code **LCWUS30**

Price **¥3,290**

Set Contains

Combination Wrench LCWU- 8, 10, 12

- Weight 55g
- Blister pack 110 × 70 × 28mm



LCWUS30

**3Pcs.**

Code **LCWUS31**

Price **¥3,150**

Set Contains

Combination Wrench LCWU- 5.5, 6, 7

- Weight 26g
- Blister pack 110 × 70 × 28mm



LCWUS31

**6Pcs.**

Code **LCWUS60**

Price **¥7,300**

Set Contains

Combination Wrench LCWU- 8, 10, 12, 13, 14, 17

- Weight 195g
- Blister pack 157 × 70 × 50mm



LCWUS60

TOOL SETS

SPANNERS

STRIKING FACE WRENCHES

HOOK SPANNERS

DX2000 TOOLS  
HEXAGON KEY WRENCHES

HEXAGON KEY WRENCHES

TORQUE WRENCHES

CROWFOOT WRENCHES

SOCKETS

OTHER TOOLS

## CL Combination Wrench, Metric

Code	mm	C mm	D mm	T <sub>1</sub> mm	T <sub>2</sub> mm	L mm	Weight g	Box	Price ¥
CL0005	5.5	12.7	10.5	2.9	5	105	13	10	1,010
CL0006	6	13.5	11.0	2.9	5.1	110	15	10	1,010
CL0007	7	15.5	12.4	3.5	5	120	17	10	1,010
CL0008	8	17.5	12.7	3.5	5.7	130	20	10	1,010
CL0009	9	19.5	14	4.2	6.2	136	31	10	1,110
CL0010	10	21.5	15.3	4.8	6.5	152	40	10	1,110
CL0011	11	23.5	17.5	5	7	161	55	10	1,220
CL0012	12	25.5	18.5	5.5	7.5	175	70	10	1,220
CL0013	13	28.0	19.5	6.0	8.0	187	80	10	1,390
CL0014	14	29.5	22.0	6.0	8.5	197	100	10	1,430
CL0016	16	34.5	23.7	6.0	9.5	220	130	5	1,710
CL0017	17	36.0	26.5	7.0	10.5	231	150	5	1,710
CL0018	18	38.0	27.5	7.3	11.0	245	180	5	1,950
CL0019	19	40.0	28.0	7.5	11.5	254	200	5	1,950
CL0021	21	44.5	31.0	8.0	12.5	290	290	5	2,620
CL0022	22	46.5	32.0	8.5	13.0	304	300	5	2,620
CL0024	24	50.5	35.0	9.0	15.0	337	380	5	3,100
CL0027	27	56.0	39.5	10.5	16.0	370	495	5	4,600
CL0030	30	62.0	43.0	11.0	18.0	410	625	5	5,900
CL0032	32	65.5	47.0	11.5	18.5	420	765	5	6,800

• Nickel Chrome Plating

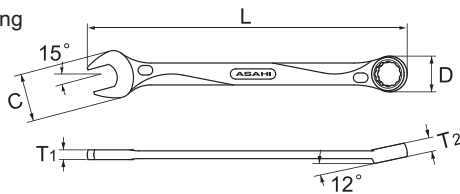

**6Pcs.**

Code **CLS060** Price **¥7,900**

Set Contains

Combination Wrench CL- 8, 10, 12, 13, 14, 17

- Weight 490g
- Plastic Holder
- Storage Box 66 × 245 × 43mm

**10Pcs.**

Code **CLS100** Price **¥18,000**

Set Contains

Combination Wrench CL-8, 10, 12, 13, 14, 17, 19, 21, 22, 24

- Weight 1750g
- Storage Box 190 × 460 × 40mm

**14Pcs.**

Code **CLS140** Price **¥33,800**

Set Contains

Combination Wrench CL- 5.5, 7, 8, 10, 12, 13, 14, 17, 19, 22, 24, 27, 30, 32

- Weight 3580g
- Tool Roll 500 × 645mm

Revowave®



Revowave features an innovative design, never seen before. The curved surface of its distinctive neck fits the worker's hand perfectly, providing excellent workability.



CLS060



CLS100

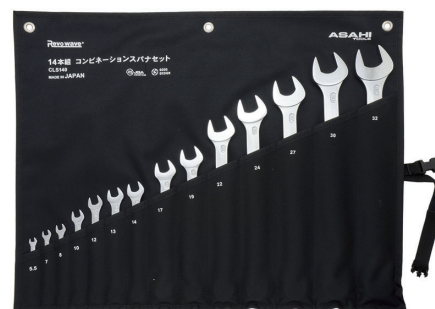

CLS140



## RS Ring Spanner, Metric

Code	mm	D mm	T mm	L mm	Weight g	Box	Price ¥
RS0010	10	16.5	8.5	163	50	10	890
RS0011	11	20	10	165	70	10	890
RS0012	12	20	10	165	70	10	940
RS0013	13	23	11	186	90	10	940
RS0014	14	23	11	186	90	10	940
RS0017	17	26.5	11.5	203	130	10	960
RS0019	19	30	12.5	215	160	10	1,000
RS0021	21	36.5	16	248	270	10	1,090
RS0022	22	36.5	16	248	270	10	1,170
RS0023	23	36.5	16	248	270	10	1,420
RS0024	24	36.5	16	248	260	10	1,420
RS0026	26	40	17	265	330	10	1,530
RS0027	27	40	17	265	320	10	1,550
RS0029	29	47	18.5	288	500	10	2,080
RS0030	30	47	18.5	288	500	10	2,080
RS0032	32	47	18.5	288	520	10	2,140
RS0035	35	54	21	312	670	5	2,520
RS0036	36	54	21	312	680	5	2,680
RS0038	38	54	21	312	680	5	3,550
RS0041	41	65.5	24	378	1,140	5	3,820
RS0046	46	65.5	24	378	1,040	5	5,200
RS0050	50	79.5	33	450	1,900	2	6,500
RS0054	54	79.5	33	450	1,850	2	11,000
RS0055	55	79.5	33	450	1,850	2	11,600
RS0058	58	93	40	521	3,130	2	13,900
RS0060	60	93	40	521	3,130	2	14,900
RS0063	63	93	40	521	3,000	2	18,200
RS0065	65	93	40	521	2,800	2	19,800
RS0067	67	110	45	555	4,000	2	21,700
RS0070	70	110	45	555	4,000	2	26,600
RS0071	71	110	45	555	3,600	2	28,000
RS0075	75	110	45	555	3,600	2	30,800
RS0077	77	110	45	555	3,600	2	32,700
RS0080	80	127	51	663	6,200	-	36,200
RS0085	85	127	51	663	6,200	-	65,500
RS0090	90	148	53	704	7,900	-	81,200
RS0095	95	148	53	704	7,900	-	86,400
RS0100	100	148	53	704	7,900	-	94,200
RS0105	105	160	55	740	9,400	-	96,800
RS0110	110	160	55	740	9,400	-	104,700
RS0115	115	172	55	776	10,700	-	-
RS0120	120	172	55	776	10,700	-	-
RS0125	125	185	60	813	13,400	-	-
RS0130	130	185	60	813	13,400	-	-
RS0135	135	198	60	849	-	-	-



The 40° curved single-end ring spanner is ideal for working in tight spaces.

Code	mm	D mm	T mm	L mm	Weight g	Box	Price ¥
RS0140	140	198	60	849	-	-	-
RS0145	145	211	65	886	-	-	-
RS0150	150	211	65	886	-	-	-
RS0155	155	224	65	922	-	-	-
RS0160	160	224	65	922	-	-	-
RS0165	165	237	70	959	-	-	-
RS0170	170	237	70	959	-	-	-
RS0175	175	250	70	995	-	-	-
RS0180	180	250	70	995	-	-	-
RS0185	185	263	75	1,032	-	-	-
RS0190	190	263	75	1,032	-	-	-
RS0195	195	276	75	1,068	-	-	-
RS0200	200	276	75	1,068	-	-	-

- Nickel Chrome Plating ( ~ 0032 )
- Cathodic Electrodeposition (0035 ~ )
- Special Order (0115 ~ )

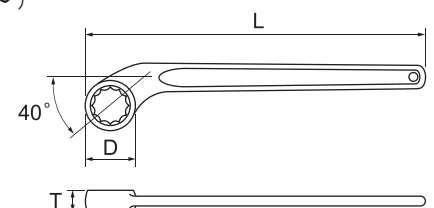

## RD Ring Spanner, Metric

Code	mm	D mm	T mm	L mm	Weight g	Box	Price ¥
RD0017	17	27	23.5	212.5	148	5	1,800
RD0019	19	32	25	233	190	5	2,040
RD0021	21	33	25.5	241.5	194	5	2,280
RD0022	22	33.5	25.5	249	214	5	2,280
RD0024	24	37	29	261.5	277	5	2,360

• Nickel Chrome Plating

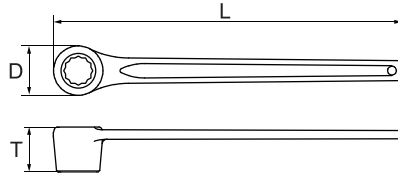

**NEW**



Allows access to fasten bolts and nuts too deep to be reached by conventional ring spanners. The larger contact surface makes it easier to transmit force and less likely to damage the surface of long nuts, etc.

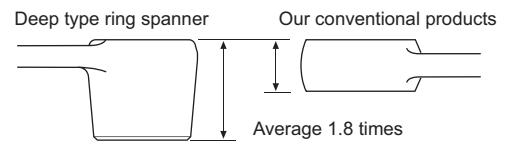

TOOL SETS

SPANNERS

STRIKING FACE WRENCHES

HOOK SPANNERS

DX2000 TOOLS  
HEXAGON KEY WRENCHES

HEXAGON KEY WRENCHES

TORQUE WRENCHES

CROWFOOT WRENCHES

SOCKETS

OTHER TOOLS

## OF Offset Wrench, Metric

Code	mm	D <sub>1</sub> mm	D <sub>2</sub> mm	T <sub>1</sub> mm	T <sub>2</sub> mm	L mm	Weight g	Box	Price ¥
OF0809	8×9	12.5	15.5	5.5	6.5	166	40	10	1,420
OF0810	8×10	12.5	15.5	5.5	6.5	166	40	10	1,420
OF1011	10×11	15.5	18.5	6.5	7.5	190	60	10	1,530
OF1012	10×12	15.5	19	6.5	7.5	190	60	10	1,430
OF1013	10×13	17	19.5	7.5	8	190	80	10	1,460
OF1113	11×13	17	19.5	7.5	8	190	80	10	1,540
OF1214	12×14	19	22	7.5	8.5	215	90	10	1,550
OF1317	13×17	21	25	8.5	10	243	140	10	1,720
OF1417	14×17	21	25	8.5	10	243	140	10	1,720
OF1719	17×19	25	28	10	11.5	276	190	10	1,920
OF1721	17×21	26.5	32	11.5	12	313	290	10	2,310
OF1921	19×21	28	32	11.5	12	314	310	10	2,430
OF1922	19×22	28	32	11.5	12	314	310	10	2,430
OF1924	19×24	29.5	34.5	12	13	332	340	10	2,580
OF2123	21×23	32	34.5	12	13	333	360	10	2,910
OF2126	21×26	32.5	38.5	13	13.5	365	450	10	3,150
OF2224	22×24	32	34.5	12	13	333	360	10	3,060
OF2326	23×26	34.5	38.5	13	13.5	366	450	5	3,430
OF2427	24×27	34.5	38.5	13	13.5	366	450	5	3,840
OF2430	24×30	38.5	46	13.5	16	392	660	5	3,950
OF2629	26×29	38.5	46	13.5	16	392	650	5	4,740
OF2632	26×32	38.5	46	13.5	16	392	600	5	4,500
OF2730	27×30	38.5	46	13.5	16	392	650	5	4,500
OF2932	29×32	46	51	16	17	428	870	5	5,030
OF3032	30×32	46	51	16	17	428	870	5	4,930
OF3235	32×35	46	51	16	17	428	870	5	5,580
OF3236	32×36	46	51	16	17	428	870	5	5,580
OF3541	35×41	51	58	17	18	455	1,120	5	7,040
OF3641	36×41	51	58	17	18	455	1,120	5	7,280

• Nickel Chrome Plating

**JIS JQA** (~ OF2427)

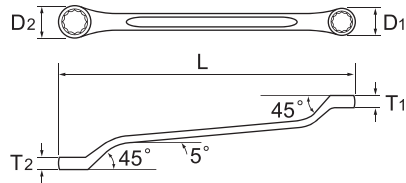

TOOL SETS

SPANNERS

STRIKING FACE WRENCHES

HOOK SPANNERS

DX2000 TOOLS  
HEXAGON KEY WRENCHES

HEXAGON KEY WRENCHES

TORQUE WRENCHES

CROWFOOT WRENCHES

SOCKETS

OTHER TOOLS

## LOF Offset Wrench, Metric

Code	mm	D <sub>1</sub> mm	D <sub>2</sub> mm	T <sub>1</sub> mm	T <sub>2</sub> mm	L mm	Weight g	Box	Price ¥
LOF0810	8×10	12.7	15.3	6	6.5	180	30	10	1,580
LOF1012	10×12	15.3	18.5	6.5	7.6	195	50	10	1,620
LOF1113	11×13	17	19.5	7.5	8	210	70	10	1,670
LOF1214	12×14	18.5	21	7.6	9.5	220	80	10	1,670
LOF1315	13×15	19.5	22.5	8	10	234	97	10	1,860
LOF1417	14×17	21	25	9.5	10.7	255	120	10	1,870
LOF1618	16×18	24	27	10.5	11.5	268	155	10	2,220
LOF1719	17×19	25	28	10.7	12.2	280	175	10	2,090
LOF1921	19×21	28	30.5	12.4	13.4	314	245	10	2,660
LOF2224	22×24	32	35	13.2	14	333	290	10	3,320

• Nickel Chrome Plating

**JIS JGA**

**PAT.**

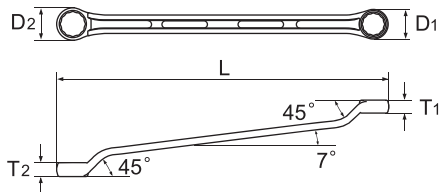

## LIGHTOOL®



LIGHTOOL is both portable and comfortable to use—an effective choice for working at high elevations or for long hours.

Achieved through painstaking testing, its optimized design and advanced forging technology ensure robust strength, which is the true hurdle of weight reduction, and its strength exceeds JIS standards.

**6Pcs.**

Code **LOFS601**

Price **¥13,200**

Set Contains

Offset Wrench | LOF-8 ×10, 10×12, 11×13, 14×17, 19×21, 22×24

- Weight 1120g
- Storage Box 175 × 375 × 40mm



TOOL SETS

SPANNERS

STRIKING FACE WRENCHES

HOOK SPANNERS

DX2000 TOOLS  
HEXAGON KEY WRENCHES

HEXAGON KEY WRENCHES



TORQUE WRENCHES

CROWFOOT WRENCHES

SOCKETS

OTHER TOOLS

## OL Offset Wrench, Metric

Code	 mm	D <sub>1</sub> mm	D <sub>2</sub> mm	T <sub>1</sub> mm	T <sub>2</sub> mm	L mm	Weight g		Price ¥
OL0810	8 × 10	12.7	15.5	6	6.5	180	47	10	1,530
OL1012	10 × 12	15.3	18.5	6.5	7.6	195	64	10	1,630
OL1113	11 × 13	17	19.5	7.5	8	210	87	10	1,750
OL1214	12 × 14	18.5	21	7.6	9.5	224	102	10	1,770
OL1417	14 × 17	21	25.5	9.5	10.7	256	169	10	2,000
OL1719	17 × 19	25.5	28	10.7	12.2	287	220	10	2,370
OL1921	19 × 21	28	30.5	12.2	13.2	314	300	10	2,910
OL2224	22 × 24	32	35	13.2	14	334	353	10	3,410

• Nickel Chrome Plating

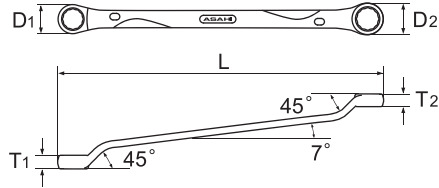

**Revowave**<sup>®</sup>



Revowave features an innovative design, never seen before. The curved surface of its distinctive neck fits the worker's hand perfectly, providing excellent workability.

**6Pcs.**

Code **OLS060**

Price **¥13,500**

Set Contains

Offset Wrench OL- 8 × 10, 10 × 12, 11 × 13, 14 × 17, 19 × 21, 22 × 24

- Weight 1200g
- Storage Box 175 × 375 × 40mm



TOOL SETS

SPANNERS

STRIKING FACE WRENCHES

HOOK SPANNERS

DX2000 TOOLS  
HEXAGON KEY WRENCHES

HEXAGON KEY WRENCHES



TORQUE WRENCHES

CROWFOOT WRENCHES

SOCKETS

OTHER TOOLS

## FW Flare Nut Wrench, Metric

Code	 mm	D <sub>1</sub> mm	D <sub>2</sub> mm	T <sub>1</sub> mm	T <sub>2</sub> mm	L mm	Weight g		Price ¥
FW0810	8×10	20	22	8.5	9	154	68	5	1,220
FW1011	10×11	20	22	8.5	9	154	65	5	1,220
FW1012	10×12	20	22	8.5	9	154	65	5	1,220
FW1113	11×13	24	26	10	11	182	115	5	1,350
FW1214	12×14	24	26	10	11	182	100	5	1,350
FW1417	14×17	28	30	11.5	12	213	155	5	1,530
FW1922	19×22	32.5	37	14	15	242	253	5	2,290

• Nickel Chrome Plating

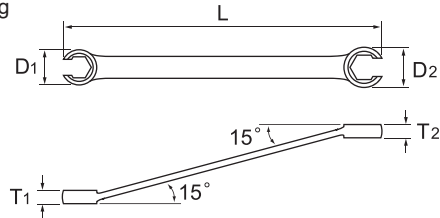

Allows fastening of nuts along a pipe.  
Handy for pipe joint work, car maintenance, and similar applications.

TOOL SETS

SPANNERS

STRIKING FACE WRENCHES

HOOK SPANNERS

DX2000 TOOLS  
HEXAGON KEY WRENCHES

HEXAGON KEY WRENCHES

TORQUE WRENCHES

CROWFOOT WRENCHES

SOCKETS

OTHER TOOLS

# Striking Face Wrenches



DR

mm	
Width across flat	
24	●
27	●
30	●
32	●
35	●
36	●
38	●
41	●
46	●
50	●
54	●
55	●
58	●
60	●
63	●
65	●
67	●
70	●
71	●
75	●
77	●
80	●
85	●
90	●
95	●
100	●
105	●
110	●
115	●
120	●
125	●
130	●
135	●
145	●
150	●
155	●
165	●
170	●
175	●
180	●
185	●
190	●
200	●

## Inch

DRX

inch	
Width across flat	
15/16	●
1	●
1-1/16	●
1-1/8	●
1-1/4	●
1-5/16	●
1-3/8	●
1-7/16	●
1-1/2	●
1-5/8	●
1-11/16	●
1-3/4	●
1-13/16	●
1-7/8	●
2	●



DS

mm	
Width across flat	
30	●
32	●
35	●
36	●
41	●
46	●
50	●
54	●
55	●
58	●
60	●
63	●
65	●
67	●
70	●
71	●
75	●
80	●
85	●
90	●
95	●
100	●
105	●
110	●
115	●
120	●
125	●
130	●
135	●
145	●
150	●
155	●
165	●
170	●
175	●
180	●
190	●
200	●
210	●



DH

mm	
Width across flat	
19.0	●
25.4	●
38.1	●



DA

mm	
Width across flat	
14	●
17	●
19	●
22	●
24	●
27	●
32	●
36	●
41	●
46	●

## DR Striking Face Ring Spanner, Metric

Code	mm	D mm	T mm	t mm	L mm	Weight g	Box	Price ¥
DR0024	24	45	18	13.5	185	350	2	4,610
DR0027	27	45	18	13.5	185	340	2	4,670
DR0030	30	55	20	15	197	520	2	5,000
DR0032	32	55	20	15	197	520	2	5,100
DR0035	35	55	20	15	197	520	2	5,500
DR0036	36	66	22	16	223	940	2	5,700
<b>NEW</b> DR0038	38	66	22	16	223	940	2	6,300
DR0041	41	66	22	16	223	940	2	6,300
DR0046	46	80	27	18	250	1,330	2	7,400
DR0050	50	80	27	18	250	1,330	2	8,700
DR0054	54	90	27	19	275	1,830	2	11,300
DR0055	55	90	27	19	275	1,830	2	11,300
DR0058	58	90	27	19	275	1,830	2	12,800
DR0060	60	104	32	24	302	2,630	2	14,300
DR0063	63	104	32	24	302	2,630	2	16,100
DR0065	65	104	32	24	302	2,630	2	16,100
DR0067	67	104	32	24	302	2,630	2	17,900
DR0070	70	120	35	28	350	4,500	2	20,200
DR0071	71	120	35	28	350	4,500	2	23,000
DR0075	75	120	35	28	350	4,500	2	23,500
DR0077	77	120	35	28	350	4,500	2	28,100
DR0080	80	127	39	28	354	4,400	2	28,800
DR0085	85	144	41	31	397	7,000	2	30,400
DR0090	90	144	41	31	397	7,000	2	36,700
DR0095	95	157	50	34	419	8,500	-	36,700
DR0100	100	157	50	34	419	8,500	-	45,900
DR0105	105	183	55	36	441	11,200	-	52,300
DR0110	110	183	55	36	441	11,200	-	63,700
DR0115	115	183	55	36	441	11,200	-	73,900
DR0120	120	185	60	38	480	13,300	-	-
DR0125	125	195	60	38	490	13,000	-	-
DR0130	130	198	60	38	492	15,500	-	-
DR0135	135	204	65	40	512	17,000	-	-
DR0145	145	217	65	40	554	18,000	-	-
DR0150	150	223	65	44	577	21,000	-	-
DR0155	155	230	65	44	585	21,000	-	-
DR0165	165	242	65	48	609	24,800	-	-
DR0170	170	254	65	48	630	-	-	-
DR0175	175	254	65	48	630	-	-	-
DR0180	180	260	70	48	648	-	-	-
DR0185	185	278	75	52	692	-	-	-
DR0190	190	278	75	52	692	-	-	-
DR0200	200	293	75	52	712	-	-	-

- Cathodic Electrodeposition
- Special Order (0120 ~ )

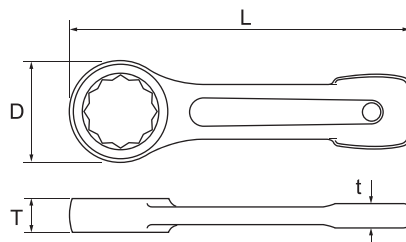

### 【 How to use 】

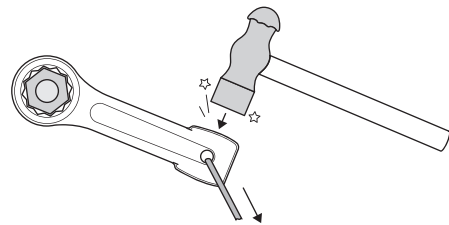

Thread a rope through the hole of the handle and pull it to a tightening direction hammering the striking surface of the spanner.



## DR Striking Face Ring Spanner, Inches

Code	inch	D mm	T mm	t mm	L mm	Weight g	Price ¥
DRX1516	15/16	45	18	13.5	185	340	2,000
DRX0101	1	45	18	13.5	185	340	2,000
DRX1716	1-1/16	45	18	13.5	185	340	2,000
DRX0908	1-1/8	55	20	15	197	520	2,800
DRX0504	1-1/4	55	20	15	197	520	2,800
DRX2116	1-5/16	55	20	15	197	520	2,800
DRX1108	1-3/8	55	20	15	197	520	2,800
DRX2316	1-7/16	66	22	16	223	940	3,200
DRX0302	1-1/2	66	22	16	223	940	3,200
DRX1308	1-5/8	66	22	16	223	940	3,200
DRX2716	1-11/16	80	27	18	250	1,330	4,000
DRX0704	1-3/4	80	27	18	250	1,330	4,000
DRX2916	1-13/16	80	27	18	250	1,330	4,000
DRX1508	1-7/8	80	27	18	250	1,330	4,000
DRX0201	2	80	27	18	250	1,330	4,000

• Cathodic Electrodeposition

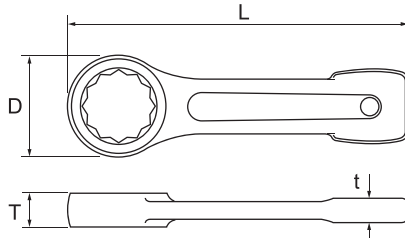

inch

NEW



TOOL SETS

SPANNERS

STRIKING FACE WRENCHES

HOOK SPANNERS

DRX2000 TOOLS  
HEXAGON KEY WRENCHES

HEXAGON KEY WRENCHES

TORQUE WRENCHES

CROWFOOT WRENCHES

SOCKETS

OTHER TOOLS

## DS Striking Face Open End Spanner, Metric

Code	mm	C mm	T mm	t mm	L mm	Weight g	Price ¥
DS0030	30	82.6	19	14	222	830	6,700
DS0032	32	82.6	19	14	222	830	6,700
DS0035	35	82.6	19	14	222	830	6,700
DS0036	36	82.6	19	14	222	830	6,700
DS0041	41	82.6	19	14	222	800	8,700
DS0046	46	113	22	18	266	1,600	10,200
DS0050	50	113	22	18	266	1,600	12,800
DS0054	54	113	22	18	266	1,550	14,300
DS0055	55	113	22	18	266	1,500	14,600
DS0058	58	150	32	24	324	4,200	16,900
DS0060	60	150	32	24	324	4,200	18,900
DS0063	63	150	32	24	324	4,200	24,000
DS0065	65	150	32	24	324	4,000	25,300
DS0067	67	150	32	24	324	4,000	27,600
DS0070	70	181	38	28	381	7,500	30,100
DS0071	71	181	38	28	381	7,500	35,000
DS0075	75	181	38	28	381	7,500	37,200
DS0077	77	181	38	28	381	7,500	40,800
DS0080	80	181	38	28	381	7,500	40,800
DS0085	85	208	45	30	429	10,000	47,500
DS0090	90	208	45	30	429	10,000	56,100
DS0095	95	208	45	30	429	10,000	57,400
DS0100	100	220	50	34	450	12,000	83,700
DS0105	105	230	50	34	470	13,000	87,900
DS0110	110	240	50	34	490	13,800	97,700
DS0115	115	245	55	34	510	14,000	115,800
DS0120	120	255	55	36	520	20,200	-
DS0125	125	270	60	36	537	22,000	-
DS0130	130	270	60	36	537	23,000	-
DS0135	135	280	60	36	560	24,000	-
DS0145	145	295	65	42	606	30,000	-
DS0150	150	305	65	42	631	32,000	-
DS0155	155	315	65	42	642	34,000	-
DS0165	165	330	75	48	671	-	-
DS0170	170	340	75	48	691	-	-
DS0175	175	360	75	48	712	-	-
DS0180	180	360	75	48	717	-	-
DS0185	185	380	75	52	759	-	-
DS0190	190	380	75	52	764	-	-
DS0200	200	400	80	54	787	-	-
DS0210	210	420	90	54	813	-	-

- Cathodic Electrodeposition
- Special Order (0120 ~ )

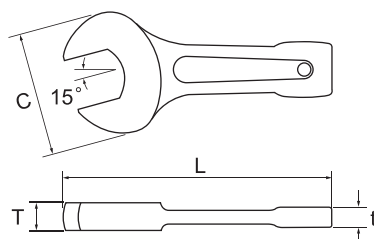

TOOL SETS

SPANNERS

STRIKING FACE WRENCHES

HOOK SPANNERS

DX2000 TOOLS  
HEXAGON KEY WRENCHES

HEXAGON KEY WRENCHES

TORQUE WRENCHES

CROWFOOT WRENCHES

SOCKETS

OTHER TOOLS

## DH Striking Face Spanner with Square Bit

Code	Ø mm	D mm	T mm	t mm	L mm	Weight g	Price ¥
DH0600	19.0	66	48	16	223	1,250	33,200
DH0800	25.4	66	52	16	223	1,300	33,200
DH1000	38.1	80	71	18	250	2,200	38,300

- Cathodic Electrodeposition
- Interchangeable
- Special Order

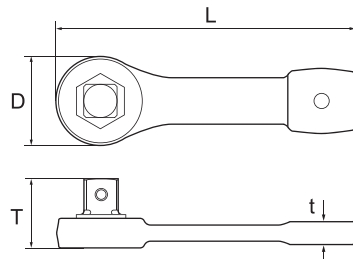

## DA Striking Face Spanner with Hex Bit, Metric

Code	Ø mm	D mm	T mm	t mm	L mm	Weight g	Price ¥
<b>NEW</b> DA1400	14	55	60	15	197	760	24,500
<b>NEW</b> DA1700	17	55	60	15	197	780	24,500
DA1900	19	66	67	16	223	1,280	25,500
DA2200	22	66	67	16	223	1,320	25,500
DA2400	24	66	67	16	223	1,350	25,500
DA2700	27	80	77	18	250	1,830	33,200
DA3200	32	80	77	18	250	1,930	33,200
DA3600	36	80	77	18	250	2,030	33,200
<b>NEW</b> DA4100	41	90	82	19	275	2,830	42,000
<b>NEW</b> DA4600	46	90	82	19	275	2,980	42,000

- Cathodic Electrodeposition
- Interchangeable
- Special Order

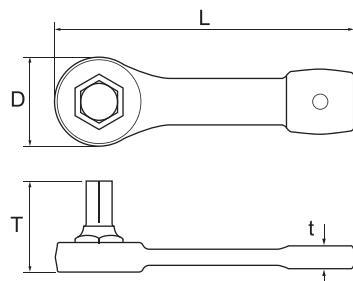

## 【 Exchange Bit 】

Code	Ø mm	D mm	L mm	Weight g		Price ¥
DAT1400	14	32	60	210	-	15,000
DAT1700	17	32	60	230	-	15,000
DAT1900	19	36	67	326	-	15,500
DAT2200	22	36	67	363	-	15,500
DAT2400	24	36	67	385	-	16,000
DAT2700	27	46	77	670	-	17,000
DAT3200	32	46	77	763	-	17,500
DAT3600	36	46	77	842	-	18,000
DAT4100	41	50	82	1,120	-	21,500
DAT4600	46	50	82	1,270	-	21,500

- For DA
- Black Oxide Finish

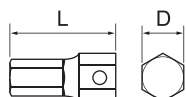

**NEW**



TOOL SETS

SPANNERS

STRIKING FACE WRENCHES

HOOK SPANNERS

DA2000 TOOLS  
HEXAGON KEY WRENCHES

HEXAGON KEY WRENCHES

TORQUE WRENCHES

CROWFOOT WRENCHES

SOCKETS

OTHER TOOLS

# Hook Spanner

Hook Spanner	
	FK
 mm	
Bearing nut diameter	
12~14	●
16~20	●
20~22	●
25~28	●
30~32	●
34~38	●
38~45	●
40~42	●
45~48	●
45~52	●
50~55	●
52~58	●
58~65	●
65~70	●
65~75	●
70~75	●
75~80	●
75~85	●
80~85	●
85~92	●
92~100	●
98~110	●
105~115	●
120~130	●
140~150	●
155~165	●
175~195	●
200~220	●
230~250	●
260~280	●
290~320	●
320~345	●
350~375	●
380~400	●

Hook Spanner, Pin Type	
	FP
 mm	
Bearing nut diameter	
12~14	
16~20	
20~22	
25~28	●
30~32	●
34~38	●
38~45	
40~42	●
45~48	●
45~52	
50~55	●
52~58	
58~65	●
65~70	●
65~75	
70~75	●
75~80	
75~85	
80~85	●
85~92	●
92~100	●
98~110	
105~115	●
120~130	
140~150	
155~165	
175~195	
200~220	
230~250	
260~280	
290~320	
320~345	
350~375	
380~400	

## FK Hook Spanner

Code	mm	C mm	T mm	H mm	L mm	Weight g	Price ¥
FK0012	12~14	2	4	12	108	25	860
FK0016	16~20	2	4	12	108	25	860
FK0020	20~22	2	4	12	108	25	860
FK0025	25~28	2.3	5	21	136	50	860
FK0030	30~32	2.3	5	21	136	50	880
FK0034	34~38	2.5	6	28	160	100	1,130
FK0038	38~45	2.5	6	30	173	100	1,170
FK0040	40~42	2.5	6	30	173	100	1,170
FK0045	45~48	2.5	6.5	36	196	150	1,310
FK0045N	45~52	2.5	6.5	36	196	150	1,360
FK0052	50~55	2.5	6.5	41	208	155	1,360
FK0052N	52~58	2.5	6.5	41	208	155	1,440
FK0058	58~65	3	7.5	46	232	229	1,570
FK0065	65~70	3	7.5	46	232	229	1,610
FK0065N	65~75	3.5	8	52	247	275	1,790
FK0070	70~75	3.5	8	52	247	275	1,700
FK0075	75~80	3.5	8	52	247	275	1,770
FK0075N	75~85	3.5	8.5	62	271	390	2,230
FK0080	80~85	3.5	8.5	62	271	390	2,230
FK0085	85~92	3.5	8.5	62	271	390	2,300
FK0092	92~100	4	8.5	68	286	400	2,380
FK0098	98~110	4	10	82	333	710	3,250
FK0105	105~115	4	10	82	333	710	3,170
FK0120	120~130	4.5	10	82	333	710	3,450
FK0140	140~150	5.5	10.5	100	385	960	5,600
FK0155	155~165	5.5	10.5	100	385	960	6,100
FK0175	175~195	6.5	12	130	466	2,100	- 12,000
FK0200	200~220	7.5	12	130	466	2,100	- 13,200
FK0230	230~250	8.5	16	162	567	3,700	- 17,100
FK0260	260~280	8.5	16	162	567	3,700	- 17,600
FK0290	290~320	12	16	196	610	-	-
FK0320	320~345	12	16	215	640	-	-
FK0350	350~375	12	16	235	680	-	-
FK0380	380~400	14	19	255	741	-	-

- Cathodic Electrodeposition
- Special Order (0290 ~ )

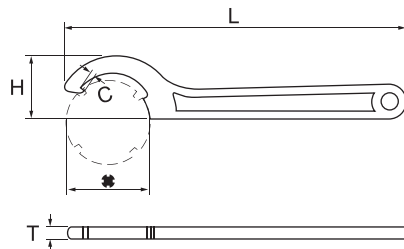

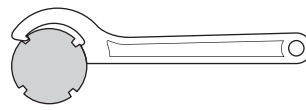

### [ How to use ]



Attach the spanner into the groove of the ring nut.

## FP Hook Spanner, Pin Type

Code	 mm	d mm	ℓ mm	T mm	H mm	L mm	Weight g		Price ¥
FP2528	25~28	2.5	2	5	21	136	50	10	1,580
FP3032	30~32	2.5	2	5	21	136	50	10	1,580
FP3438	34~38	3.5	3.5	6	28	160	100	10	1,580
FP4042	40~42	3.5	3.5	6	30	173	100	10	1,710
FP4548	45~48	4.5	4	6.5	34	195	150	10	1,960
FP5255	50~55	4.5	4	6.5	40	208	150	10	2,080
FP5865	58~65	4.5	5	7.5	46	230	220	10	2,280
FP6570	65~70	4.5	5	7.5	46	230	220	10	2,430
FP7075	70~75	5.5	5	8	52	246	275	10	2,430
FP8085	80~85	5.5	6	8.5	62	270	390	10	3,040
<b>NEW</b> FP8592	85~92	5.5	6	8.5	62	270	390	10	3,150
FP9298	92~100	6	6	8.5	68	286	400	10	3,260
FPP105	105~115	6	6	10	82	333	710	5	6,010



• Cathodic Electrodeposition

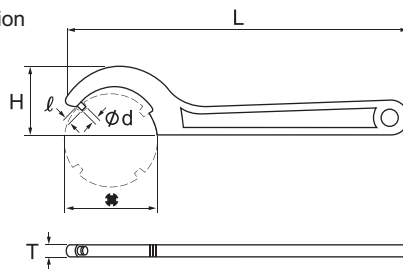

Do not attach the spanner into the narrow groove as it may damage the spanner.

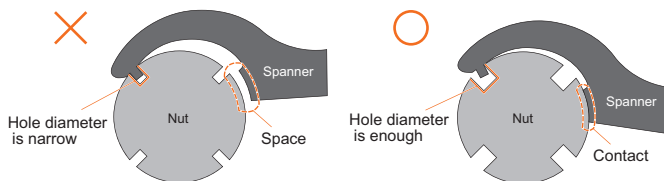

TOOL SETS

SPANNERS

STRIKING FACE WRENCHES

HOOK SPANNERS

DX2000 TOOLS  
HEXAGON KEY WRENCHES

HEXAGON KEY WRENCHES

TORQUE WRENCHES

CROWFOOT WRENCHES

SOCKETS

OTHER TOOLS

**DX2000**TOOLS  
Hexagon Key Wrenches

**[Metric]**

		AQ	AQU	AZ	AZU	AY	AX	DY	DZ	DV	DV	DW	DW	AQK	AZK	AYK
Length	Long	●	●			●		●		●	●			●		●
	Short			●	●		●		●			●	●		●	
Functions	Ball Point	●	●	●	●					●	●	●	●	●	●	
	<b>Auroline</b> Different Colors For Each Size		●		●											
	<b>Daxkey Wrench</b> Half-Length Hex Key Ends							●	●	●	●	●	●			
	Double-Ended							●	●							
	Bent On Edges									●	●	●	●			
	Catcher Ball										●		●	●	●	●
Size mm	1.5	●	●	●	●	●	●	●	●	●		●				
	2	●	●	●	●	●	●	●	●	●		●				
	2.5	●	●	●	●	●	●	●	●	●		●				
	3	●	●	●	●	●	●	●	●		●		●	●	●	●
	4	●	●	●	●	●	●	●	●		●		●	●	●	●
	5	●	●	●	●	●	●	●	●		●		●	●	●	●
	6	●	●	●	●	●	●	●	●		●		●	●	●	●
	8	●	●	●	●	●	●	●	●		●		●	●	●	●
	10	●	●	●	●	●	●	●	●		●		●	●	●	●
	12	●		●		●	●				●					
	14	●		●		●	●				●					
	17	●				●					●					
19	●				●					●						

**[Inch]**

		AQX	AQKX
Length	Long	●	●
	Ball Point	●	●
	Catcher Ball		●
	1/16	●	
	5/64	●	
	3/32	●	
	1/8	●	●
	5/32	●	●
	3/16	●	●
	7/32	●	●
	1/4	●	●
	5/16	●	●
	3/8	●	●

# Ball Point

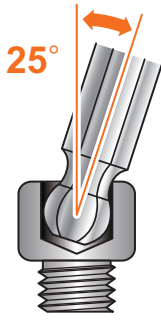

Designed to be used at an angle off-axis to the screw by 25 degrees, so as to avoid obstacles.

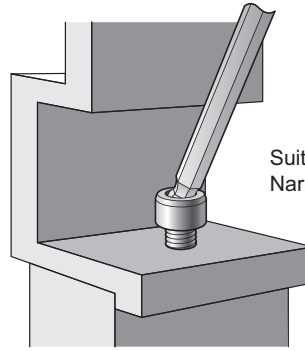

Suitable for Working in Narrow Spaces

## Long type

Code	Ø <sub>mm</sub>	L <sub>mm</sub>	ℓ <sub>mm</sub>	Weight <sub>g</sub>		Price <sub>¥</sub>
AQ0150	1.5	90	14	1.4	10	750
AQ0200	2	100	16	3	10	750
AQ0250	2.5	112	18	5.2	10	770
AQ0300	3	126	20	8.8	10	770
AQ0400	4	142	23	16	10	860
AQ0500	5	160	28	30	10	1,010
AQ0600	6	180	32	50	10	1,330
AQ0800	8	200	36	100	10	1,690
AQ1000	10	224	40	178	10	2,310
AQ1200	12	250	45	290	3	3,630
AQ1400	14	280	56	448	3	4,540
AQ1700	17	320	63	754	4	7,780
AQ1900	19	360	70	1,055	4	10,280

- Special Alloy Steel ( ~ 0600 )
- Alloy Steel ( 0800 ~ )
- Nickel Chrome Plating
- Blister pack ( 0150 ~ 1400 )



Code	Ø <sub>inch</sub>	L <sub>mm</sub>	ℓ <sub>mm</sub>	Weight <sub>g</sub>		Price <sub>¥</sub>
AQX0116	1/16	90	14	1.5	10	820
AQX0564	5/64	100	16	3	10	820
AQX0332	3/32	112	18	5	10	850
AQX0108	1/8	126	20	9.5	10	880
AQX0532	5/32	142	23	16.5	10	990
AQX0316	3/16	160	28	28	10	1,150
AQX0732	7/32	170	30	41	10	1,480
AQX0104	1/4	180	32	58	10	1,480
AQX0516	5/16	200	36	99	10	1,850
AQX0308	3/8	224	40	163	10	2,740

- Special Alloy Steel ( ~ 0316 )
- Alloy Steel ( 0732 ~ )
- Nickel Chrome Plating

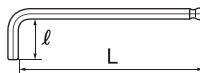

inch



TOOL SETS

SPANNERS

STRIKING FACE WRENCHES

HOOK SPANNERS

DX2000 TOOLS  
HEXAGON KEY WRENCHES

HEXAGON KEY WRENCHES

TORQUE WRENCHES

CROWFOOT WRENCHES

SOCKETS

OTHER TOOLS



# Ballpoint Hexagon Key Wrench

## Long type

**7Pcs.**

1.5 mm 2 mm 2.5 mm 3 mm 4 mm 5 mm 6 mm

Code	mm	Weight g	Box	Price ¥
AQS0710	AQ-1.5, 2, 2.5, 3, 4, 5, 6	140	10	6,450

- Plastic Holder
- Blister pack 240 × 75 × 15mm



AQS0710

**8Pcs.**

1.5 mm 2 mm 2.5 mm 3 mm 4 mm 5 mm 6 mm 8 mm

Code	mm	Weight g	Box	Price ¥
AQS0880	AQ-1.5, 2, 2.5, 3, 4, 5, 6, 8	252	5	8,240

- Plastic Holder
- Blister pack 265 × 90 × 18mm



AQS0880

**8Pcs.**

3 mm 4 mm 5 mm 6 mm 8 mm 10 mm 12 mm 14 mm

Code	mm	Weight g	Box	Price ¥
AQS0810	AQ-3, 4, 5, 6, 8, 10, 12, 14	1,240	—	16,170

- Tool Roll 310 × 285mm

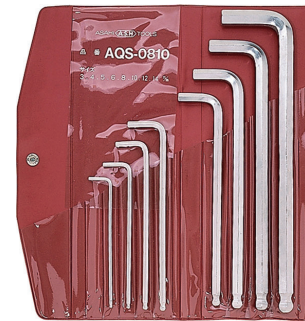

AQS0810

**9Pcs.**

1.5 mm 2 mm 2.5 mm 3 mm 4 mm 5 mm 6 mm 8 mm 10 mm

Code	mm	Weight g	Box	Price ¥
AQS0910	AQ-1.5, 2, 2.5, 3, 4, 5, 6, 8, 10	450	5	10,530

- Plastic Holder
- Blister pack 290 × 90 × 30mm



AQS0910

**9Pcs.**

1.5 mm 2 mm 2.5 mm 3 mm 4 mm 5 mm 6 mm 8 mm 10 mm

Code	mm	Weight g	Box	Price ¥
AQS0900	AQ-1.5, 2, 2.5, 3, 4, 5, 6, 8, 10	835	—	14,560

- Plastic holder with the magnet



AQS0900

**9Pcs.**

1/16 5/64 3/32 1/8 5/32 3/16 1/4 5/16 3/8

Code	inch	Weight g	Box	Price ¥
AQSE910	AQX-1/16, 5/64, 3/32, 1/8, 5/32, 3/16, 1/4, 5/16, 3/8	395	5	12,080

- Plastic Holder
- Blister pack 265 × 90 × 30mm

inch



AQSE910

TOOL SETS

SPANNERS

STRIKING FACE WRENCHES

HOOK SPANNERS

DX2000 TOOLS

HEXAGON KEY WRENCHES

TORQUE WRENCHES

CROWFOOT WRENCHES

SOCKETS

OTHER TOOLS

# Ballpoint Hexagon Key Wrenches

## Different Colors For Each Size / Long type

Code	Ø mm	L mm	ℓ mm	Weight g		Price ¥
AQU0150	1.5	90	14	1.4	-	780
AQU0200	2	100	16	3	-	780
AQU0250	2.5	112	18	5.2	-	800
AQU0300	3	126	20	8.8	-	800
AQU0400	4	142	23	16	-	880
AQU0500	5	160	28	30	-	1,040
AQU0600	6	180	32	50	-	1,370
AQU0800	8	200	36	100	-	1,750
AQU1000	10	224	40	178	-	2,390

- Special Alloy Steel ( ~ 0600 )
- Alloy Steel ( 0800 ~ )
- Nickel Chrome Plating
- Baking Finish



Auroline®

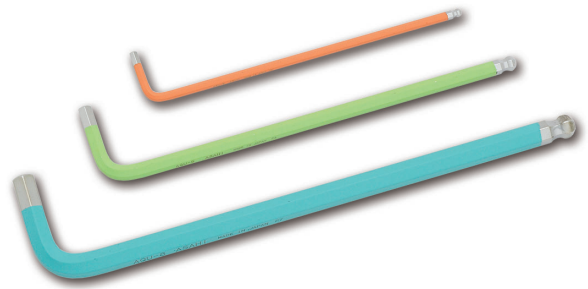

**7Pcs.**



Code	Ø mm	Weight g		Price ¥
AQUS710	AQU-1.5, 2, 2.5, 3, 4, 5, 6	140	10	7,250

- Plastic Holder
- Blister pack 240 × 75 × 15mm

**NEW**



AQUS710

**9Pcs.**



Code	Ø mm	Weight g		Price ¥
AQUS910	AQU-1.5, 2, 2.5, 3, 4, 5, 6, 8, 10	420	5	10,900

- Plastic Holder
- Blister pack 290 × 90 × 25mm



AQUS910

TOOL SETS

SPANNERS

STRIKING FACE WRENCHES

HOOK SPANNERS

DX2000 TOOLS  
HEXAGON KEY WRENCHES

HEXAGON KEY WRENCHES

TORQUE WRENCHES

CROWFOOT WRENCHES

SOCKETS

OTHER TOOLS

# Ballpoint Hexagon Key Wrenches

## Short type

Code	○ mm	L mm	ℓ mm	Weight g		Price ¥
AZ0150	1.5	50	14	1	10	630
AZ0200	2	56	16	1.8	10	630
AZ0250	2.5	63	18	3.2	10	650
AZ0300	3	71	20	5.4	10	650
AZ0400	4	80	22	10	10	670
AZ0500	5	90	25	18	10	760
AZ0600	6	100	28	30	10	900
AZ0800	8	112	32	62	10	1,200
AZ1000	10	125	36	110	10	1,570
AZ1200	12	140	40	176	3	3,000
AZ1400	14	160	45	280	3	3,400

- Special Alloy Steel ( ~ 0600)
- Alloy Steel (0800 ~ )
- Nickel Chrome Plating
- Blister pack

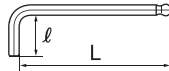

**7Pcs.**

1.5 mm 2 mm 2.5 mm 3 mm 4 mm 5 mm 6 mm

Code	○ mm	Weight g		Price ¥
AZS0710	AZ-1.5, 2, 2.5, 3, 4, 5, 6	100	10	5,080

- Plastic Holder
- Blister pack 165 × 75 × 15mm



AZS0710

**8Pcs.**

3 mm 4 mm 5 mm 6 mm 8 mm 10 mm 12 mm 14 mm

Code	○ mm	Weight g		Price ¥
AZS0810	AZ-3, 4, 5, 6, 8, 10, 12, 14	800	—	12,010

- Tool Roll 215 × 270mm



AZS0810

**9Pcs.**

1.5 mm 2 mm 2.5 mm 3 mm 4 mm 5 mm 6 mm 8 mm 10 mm

Code	○ mm	Weight g		Price ¥
AZS0910	AZ-1.5, 2, 2.5, 3, 4, 5, 6, 8, 10	280	5	8,020

- Plastic Holder
- Blister pack 190 × 90 × 30mm



AZS0910

TOOL SETS

SPANNERS

STRIKING FACE WRENCHES

HOOK SPANNERS

DX2000 TOOLS  
HEXAGON KEY WRENCHES

HEXAGON KEY WRENCHES

TORQUE WRENCHES

CROWFOOT WRENCHES

SOCKETS

OTHER TOOLS

# Ballpoint Hexagon Key Wrenches

## Different Colors For Each Size / Short type

Code	Ø mm	L mm	ℓ mm	Weight g		Price ¥
AZU0150	1.5	50	14	1	-	730
AZU0200	2	56	16	1.8	-	730
AZU0250	2.5	63	18	3.2	-	750
AZU0300	3	71	20	5.4	-	750
AZU0400	4	80	22	10	-	780
AZU0500	5	90	25	18	-	880
AZU0600	6	100	28	30	-	1,040
AZU0800	8	112	32	62	-	1,380
AZU1000	10	125	36	110	-	1,810

- Special Alloy Steel ( ~ 0600 )
- Alloy Steel ( 0800 ~ )
- Nickel Chrome Plating
- Baking Finish



Auroline®

NEW

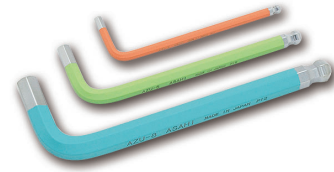

TOOL SETS

SPANNERS

STRIKING FACE WRENCHES

HOOK SPANNERS

DX2000 TOOLS  
HEXAGON KEY WRENCHES

HEXAGON KEY WRENCHES

TORQUE WRENCHES

CROWFOOT WRENCHES

SOCKETS

OTHER TOOLS

7Pcs.

1.5 mm 2 mm 2.5 mm 3 mm 4 mm 5 mm 6 mm

Code	Ø mm	Weight g		Price ¥
AZUS710	AZU-1.5, 2, 2.5, 3, 4, 5, 6	100	10	6,500

- Plastic Holder
- Blister pack 165 × 75 × 15mm

NEW



AZUS710

9Pcs.

1.5 mm 2 mm 2.5 mm 3 mm 4 mm 5 mm 6 mm 8 mm 10 mm

Code	Ø mm	Weight g		Price ¥
AZUS910	AZU-1.5, 2, 2.5, 3, 4, 5, 6, 8, 10	280	5	9,650

- Plastic Holder
- Blister pack 190 × 90 × 25mm

NEW



AZUS910

# Hexagon Key Wrenches

## Long type

Code	○ mm	L mm	ℓ mm	Weight g		Price ¥
AY0150	1.5	90	14	1.4	10	340
AY0200	2	100	16	3	10	340
AY0250	2.5	112	18	5.2	10	360
AY0300	3	126	20	8.8	10	410
AY0400	4	142	23	16	10	490
AY0500	5	160	28	30	10	680
AY0600	6	180	32	50	10	1,050
AY0800	8	200	36	100	10	1,360
AY1000	10	224	40	178	10	1,980
AY1200	12	250	45	290	3	2,840
AY1400	14	280	56	448	3	3,860
AY1700	17	320	63	754	4	4,900
AY1900	19	360	70	1,055	4	7,410

- Special Alloy Steel ( ~ 0600)
- Alloy Steel (0800 ~ )
- Nickel Chrome Plating
- Blister pack (0150 ~ 1400)



**7Pcs.**

1.5 mm 2 mm 2.5 mm 3 mm 4 mm 5 mm 6 mm

Code	○ mm	Weight g		Price ¥
AYS0710	AY-1.5, 2, 2.5, 3, 4, 5, 6	150	10	3,770

- Plastic Holder
- Blister pack 240 × 75 × 15mm



AYS0710

**8Pcs.**

3 mm 4 mm 5 mm 6 mm 8 mm 10 mm 12 mm 14 mm

Code	○ mm	Weight g		Price ¥
AYS0810	AY-3, 4, 5, 6, 8, 10, 12, 14	1,270	—	12,700

- Tool Roll 310 × 285mm



AYS0810

**9Pcs.**

1.5 mm 2 mm 2.5 mm 3 mm 4 mm 5 mm 6 mm 8 mm 10 mm

Code	○ mm	Weight g		Price ¥
AYS0910	AY-1.5, 2, 2.5, 3, 4, 5, 6, 8, 10	450	5	7,360

- Plastic Holder
- Blister pack 290 × 90 × 30mm



AYS0910

TOOL SETS

SPANNERS

STRIKING FACE WRENCHES

HOOK SPANNERS

HEXAGON KEY WRENCHES

HEXAGON KEY WRENCHES

TORQUE WRENCHES

CROWFOOT WRENCHES

SOCKETS

OTHER TOOLS

# Hexagon Key Wrenches

## Short type

Code	φ mm	L mm	ℓ mm	Weight g		Price ¥
AX0150	1.5	50	14	1	10	270
AX0200	2	56	16	1.8	10	270
AX0250	2.5	63	18	3.2	10	280
AX0300	3	71	20	5.4	10	290
AX0400	4	80	22	10	10	310
AX0500	5	90	25	18	10	380
AX0600	6	100	28	30	10	520
AX0800	8	112	32	62	10	750
AX1000	10	125	36	110	10	1,200
AX1200	12	140	40	176	3	2,390
AX1400	14	160	45	280	3	3,070

- Special Alloy Steel ( ~ 0600)
- Alloy Steel (0800 ~ )
- Nickel Chrome Plating
- Blister pack

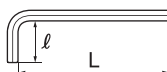

**7Pcs.**

1.5 mm 2 mm 2.5 mm 3 mm 4 mm 5 mm 6 mm

Code	φ mm	Weight g		Price ¥
AXS0710	AX-1.5, 2, 2.5, 3, 4, 5, 6	100	10	2,680

- Plastic Holder
- Blister pack 165 × 75 × 15mm



AXS0710

**8Pcs.**

3 mm 4 mm 5 mm 6 mm 8 mm 10 mm 12 mm 14 mm

Code	φ mm	Weight g		Price ¥
AXS0810	AX-3, 4, 5, 6, 8, 10, 12, 14	800	—	8,780

- Tool Roll 215 × 270mm



AXS0810

**9Pcs.**

1.5 mm 2 mm 2.5 mm 3 mm 4 mm 5 mm 6 mm 8 mm 10 mm

Code	φ mm	Weight g		Price ¥
AXS0910	AX-1.5, 2, 2.5, 3, 4, 5, 6, 8, 10	290	5	4,530

- Plastic Holder
- Blister pack 190 × 90 × 30mm



AXS0910

TOOL SETS

SPANNERS

STRIKING FACE WRENCHES

HOOK SPANNERS

DX2000 TOOLS  
HEXAGON KEY WRENCHES

HEXAGON KEY WRENCHES

TORQUE WRENCHES

CROWFOOT WRENCHES

SOCKETS

OTHER TOOLS

## Double-Ended

This product only requires only 30 degrees turning angle (half of normal space), as both ends are bent twisted 90 degrees opposite angle. Please use the both end interchangeably to work continuously.

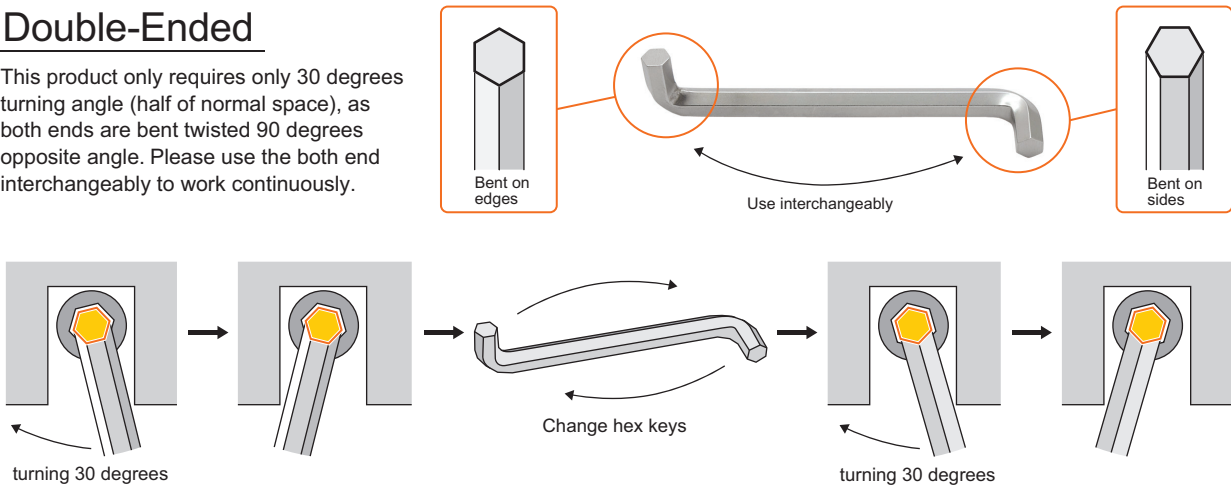

## Long type

Code	mm	L mm	l mm	Weight g	Box	Price ¥
DY0150	1.5	90	6	1.5	10	910
DY0200	2	100	6.5	2.5	10	910
DY0250	2.5	112	8	5	10	910
DY0300	3	126	10	8	10	910
DY0400	4	142	12	17	10	990
DY0500	5	160	14	30	10	1,130
DY0600	6	180	18	57	10	1,450
DY0800	8	200	23	100	10	1,900
DY1000	10	224	27.5	183	10	2,720

- Special Alloy Steel ( ~ 0300 )
- Alloy Steel ( 0400 ~ )
- Nickel Chrome Plating
- Blister pack

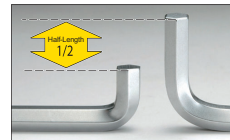
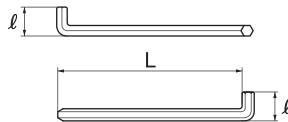

Our hex key ends are shorter than existing products (approximately half of the length), and it ensures space-constrained work.

**9Pcs.**

1.5 mm 2 mm 2.5 mm 3 mm 4 mm 5 mm 6 mm 8 mm 10 mm

Code	mm	Weight g	Box	Price ¥
DYS0910	DY-1.5, 2, 2.5, 3, 4, 5, 6, 8, 10	400	5	9,790

- Plastic Holder
- Blister pack 290 × 90 × 50mm

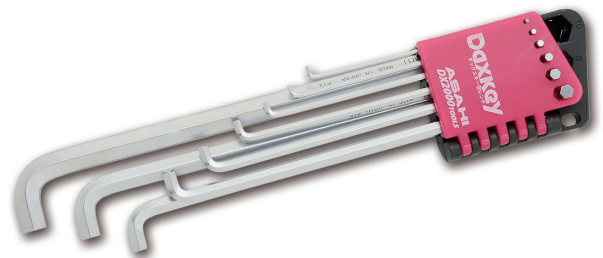

# Daxkey Wrench Double-Ended

## Short type

Code	Ø mm	L mm	ℓ mm	Weight g		Price ¥
DZ0150	1.5	50	6	0.8	10	860
DZ0200	2	56	6.5	1.7	10	860
DZ0250	2.5	63	8	3	10	860
DZ0300	3	71	10	5	10	860
DZ0400	4	80	12	10	10	940
DZ0500	5	90	14	18	10	1,080
DZ0600	6	100	18	30	10	1,370
DZ0800	8	112	23	62	10	1,800
DZ1000	10	125	27.5	105	10	2,580

- Special Alloy Steel ( ~ 0300 )
- Alloy Steel (0400 ~ )
- Nickel Chrome Plating
- Blister pack

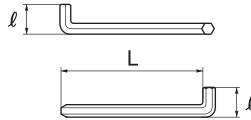

**9Pcs.**

1.5 mm 2 mm 2.5 mm 3 mm 4 mm 5 mm 6 mm 8 mm 10 mm

Code	Ø mm	Weight g		Price ¥
DZS0910	DZ-1.5, 2, 2.5, 3, 4, 5, 6, 8, 10	270	5	9,320

- Plastic Holder
- Blister pack 190 × 90 × 50mm

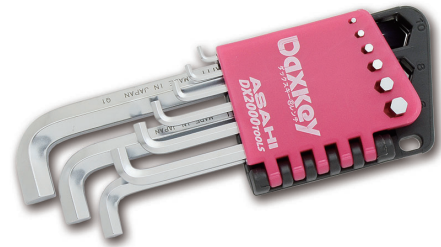

TOOL SETS

SPANNERS

STRIKING FACE WRENCHES

HOOK SPANNERS

DAX2000 TOOLS  
HEXAGON KEY WRENCHES

HEXAGON KEY WRENCHES

TORQUE WRENCHES

CROWFOOT WRENCHES

SOCKETS

OTHER TOOLS



## Bent On Edges

Our products are bent on its edges; existing products are usually bent on its sides. Designed to be used continuously at 30 degrees rotation angle using interchangeably to an existing hex key.

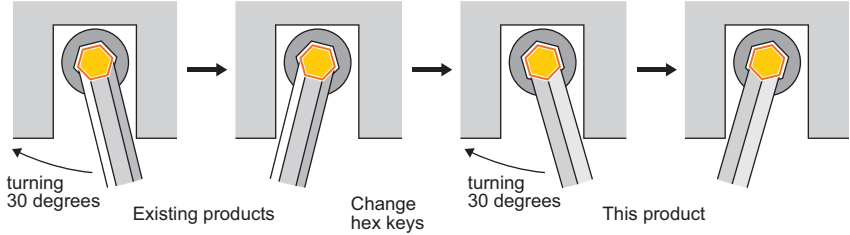
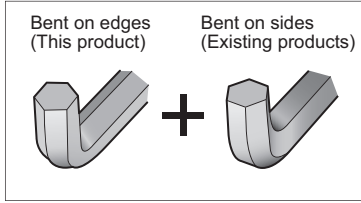

## Half-Length Hex Key Ends

Our hex key ends are shorter than existing products (approximately half of the length), and it ensures space-constrained work.



Make a huge difference in working in a narrow space

## Ballpoint / Long type

without Catcher Ball

Code	Ø mm	L mm	ℓ mm	Weight g	Box	Price ¥
DV0150	1.5	90	6	1.3	10	930
DV0200	2	100	6.5	2.7	10	930
DV0250	2.5	112	8	5	10	950

with Catcher Ball

Code	Ø mm	L mm	ℓ mm	Weight g	Box	Price ¥
DV0300	3	126	10	8	10	980
DV0400	4	142	12	16	10	1,050
DV0500	5	160	14	25	10	1,190
DV0600	6	180	18	48	10	1,510
DV0800	8	200	23	90	10	1,900
DV1000	10	224	27.5	160	10	2,710
DV1200	12	250	34	270	5	4,250
DV1400	14	280	41	410	5	5,320
DV1700	17	320	48	690	5	9,110
DV1900	19	360	53	970	5	12,030

- Special Alloy Steel ( ~ 0300)
- Alloy Steel (0400 ~ )
- Nickel Chrome Plating
- Blister pack (0150 ~ 1000)



9Pcs.

1.5 mm	2 mm	2.5 mm	3 mm	4 mm	5 mm	6 mm	8 mm	10 mm
without Catcher Ball			with Catcher Ball					

Code	Ø mm	Weight g	Box	Price ¥
DVS0910	DV-1.5, 2, 2.5, 3, 4, 5, 6, 8, 10	395	5	11,730

- Plastic Holder
- Blister pack 290 × 90 × 50mm



# Daxkey Wrench Bent On Edges

## Ballpoint / Short type

### without Catcher Ball

Code	Ø mm	L mm	ℓ mm	Weight g		Price ¥
DW0150	1.5	50	6	0.7	10	790
DW0200	2	56	6.5	1.6	10	790
DW0250	2.5	63	8	2.8	10	810

### with Catcher Ball

Code	Ø mm	L mm	ℓ mm	Weight g		Price ¥
DW0300	3	71	10	4.6	10	830
DW0400	4	80	12	9.5	10	860
DW0500	5	90	14	16	10	930
DW0600	6	100	18	26	10	1,070
DW0800	8	112	23	55	10	1,340
DW1000	10	125	27.5	95	10	1,790

- Special Alloy Steel ( ~ 0300 )
- Alloy Steel (0400 ~ )
- Nickel Chrome Plating
- Blister pack



**9Pcs.**

1.5 mm	2 mm	2.5 mm	3 mm	4 mm	5 mm	6 mm	8 mm	10 mm
without Catcher Ball			with Catcher Ball					

Code	Ø mm	Weight g		Price ¥
DWS0910	DW-1.5, 2, 2.5, 3, 4, 5, 6, 8, 10	245	5	9,500

- Plastic Holder
- Blister pack 190 × 90 × 50mm



TOOL SETS

SPANNERS

STRIKING FACE WRENCHES

HOOK SPANNERS

HEXAGON KEY WRENCHES

HEXAGON KEY WRENCHES

TORQUE WRENCHES

CROWFOOT WRENCHES

SOCKETS

OTHER TOOLS

## Catcher Ball

A spring suspension and a steel ball implanted by a high-precision processing technology holds the bolt securely. The bolt is firmly secured and does not need to be held by a hand before or after tightening, or during work in an inaccessible place.

(It corresponds to 3mm from 10mm)

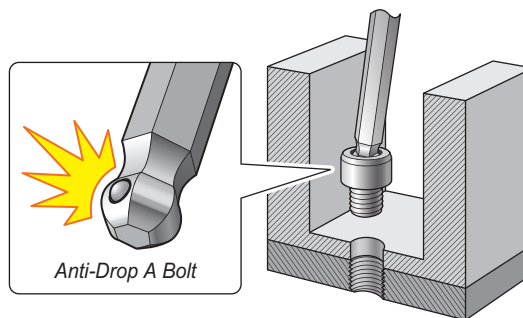

## Ballpoint / Long type

Code	Ø mm	L mm	ℓ mm	Weight g	Box	Price ¥
AQK0300	3	126	20	9	10	850
AQK0400	4	142	23	16	10	920
AQK0500	5	160	28	30	10	1,090
AQK0600	6	180	32	50	10	1,430
AQK0800	8	200	36	100	10	1,820
AQK1000	10	224	40	180	10	2,500

- Special Alloy Steel ( ~ 0600 )
- Alloy Steel (0800 ~ )
- Nickel Chrome Plating
- Blister pack



Code	Ø inch	L mm	ℓ mm	Weight g	Box	Price ¥
AQKX108	1/8	126	20	10	10	970
AQKX532	5/32	142	23	17	10	1,090
AQKX316	3/16	160	28	29	10	1,270
AQKX104	1/4	180	32	57	10	1,630
AQKX516	5/16	200	36	98	10	2,040
AQKX308	3/8	224	40	160	10	3,020

- Special Alloy Steel ( ~ 316 )
- Alloy Steel (104 ~ )
- Nickel Chrome Plating



## 7Pcs.

1.5 mm	2 mm	2.5 mm	3 mm	4 mm	5 mm	6 mm
without Catcher Ball			with Catcher Ball			

Code	Ø mm	Weight g	Box	Price ¥
AQKS710	AQ-1.5, 2, 2.5 AQK-3, 4, 5, 6	130	10	6,870

- Plastic Holder
- Blister pack 240 × 75 × 15mm



AQKS710

## 9Pcs.

1.5 mm	2 mm	2.5 mm	3 mm	4 mm	5 mm	6 mm	8 mm	10 mm
without Catcher Ball			with Catcher Ball					

Code	Ø mm	Weight g	Box	Price ¥
AQKS910	AQ-1.5, 2, 2.5 AQK-3, 4, 5, 6, 8, 10	420	5	11,340

- Plastic Holder
- Blister pack 290 × 90 × 30mm



AQKS910

# Catcher® Wrench Catcher Ball

## Ballpoint / Long type

**9Pcs.**

1/16	5/64	3/32	1/8	5/32	3/16	1/4	5/16	3/8
without Catcher Ball			with Catcher Ball					

inch

NEW

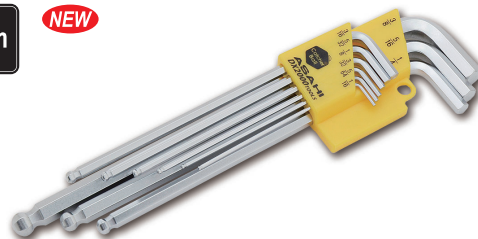

Code	mm	Weight g	Box	Price ¥
AQKSE91	AQX-1/16, 5/64, 3/32 AQKX-1/8, 5/32, 3/16, 1/4, 5/16, 3/8	400	5	14,200

- Plastic Holder
- Blister pack 265 × 90 × 30mm

## Ballpoint / Short type

Code	mm	L mm	ℓ mm	Weight g	Box	Price ¥
AZK0300	3	71	20	5.5	10	730
AZK0400	4	80	22	10	10	750
AZK0500	5	90	25	18	10	840
AZK0600	6	100	28	30	10	1,000
AZK0800	8	112	32	62	10	1,330
AZK1000	10	125	36	110	10	1,760

- Special Alloy Steel ( ~ 0600 )
- Alloy Steel (0800 ~ )
- Nickel Chrome Plating

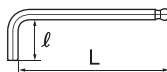

**9Pcs.**

1.5 mm	2 mm	2.5 mm	3 mm	4 mm	5 mm	6 mm	8 mm	10 mm
without Catcher Ball			with Catcher Ball					

Code	mm	Weight g	Box	Price ¥
AZKS910	AZ-1.5, 2, 2.5 AZK-3, 4, 5, 6, 8, 10	280	5	8,760

- Plastic Holder
- Blister pack 190 × 90 × 30mm



## Long type

Code	mm	L mm	ℓ mm	Weight g	Box	Price ¥
AYK0300	3	126	20	9	10	490
AYK0400	4	142	23	16	10	570
AYK0500	5	160	28	30	10	760
AYK0600	6	180	32	50	10	1,150
AYK0800	8	200	36	100	10	1,490
AYK1000	10	224	40	180	10	2,170

- Special Alloy Steel ( ~ 0600 )
- Alloy Steel (0800 ~ )
- Nickel Chrome Plating
- Blister pack



**9Pcs.**

1.5 mm	2 mm	2.5 mm	3 mm	4 mm	5 mm	6 mm	8 mm	10 mm
without Catcher Ball			with Catcher Ball					

Code	mm	Weight g	Box	Price ¥
AYKS910	AY-1.5, 2, 2.5 AYK-3, 4, 5, 6, 8, 10	410	5	7,960

- Plastic Holder
- Blister pack 290 × 90 × 30mm

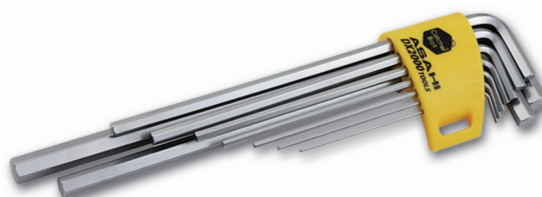

TOOL SETS

SPANNERS

STRIKING FACE WRENCHES

HOOK SPANNERS

DX2000 TOOLS  
HEXAGON KEY WRENCHES

HEXAGON KEY WRENCHES

TORQUE WRENCHES









CROWFOOT WRENCHES

SOCKETS

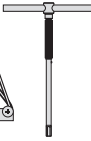

OTHER TOOLS

# Hexagon Key Wrenches

## [Metric]

										
		AW	AL	EX	AP	APTS	ARS	ANS	VTH	ATL
Length	Short	●					●			
	Long		●	●						
	Standard				●	●				
Functions	Ball Point				●	●				
	Catcher Ball					●				
	Set On Ring						●			
Shape	Convenient Holder							●		
	T-Handled								●	●
	Separate Type								●	
Size $\text{mm}$	0.71			●						
	0.89			●						
	1.27			●						
	1.5	●	●		●					
	2	●	●		●					
	2.5	●	●		●					●
	3	●	●		●				●	●
	4	●	●		●				●	●
	5	●	●		●				●	●
	6	●	●		●				●	●
	7	●								
	8	●	●		●				●	
	10	●	●		●					
	12	●	●		●					
	14	●	●		●					
	16	●								
	17	●	●		●					
	19	●	●		●					
	21	●								
	22	●			●					
	24	●			●					
	26	●								
	27	●			●					
32	●			●						
36	●			●						
41	●									
46	●									
50	●									

## [Inch]

				
		AWX	ARSE	ANS
Short		●		
Set On Ring			●	
Convenient Holder				●
1/16		●		
5/64		●		
3/32		●		
1/8		●		
5/32		●		
3/16		●		
7/32		●		
1/4		●		
5/16		●		
3/8		●		
7/16		●		
1/2		●		

## [Hexlobe]

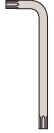
		
		ATX
T10H		●
T15H		●
T20H		●
T25H		●
T27H		●
T30H		●
T40H		●

# Hexagon Key Wrench

## Short type

Code	⌀ mm	L mm	ℓ mm	Weight g		Price ¥
AW0150	1.5	45	14	0.8	100	64
AW0200	2	50	16	1.8	100	64
AW0250	2.5	56	18	3	100	64
AW0300	3	63	20	5	100	64
AW0400	4	72	23	10	100	70
AW0500	5	80	28	18	100	82
AW0600	6	90	32	28	100	104
AW0700	7	95	34	42	50	144
AW0800	8	100	36	60	50	166
AW1000	10	112	40	105	50	260
AW1200	12	125	45	170	30	420
AW1400	14	140	56	266	10	620
AW1600	16	157	63	400	10	1,470
AW1700	17	160	63	446	10	950
AW1900	19	180	70	624	10	1,770
AW2100	21	198	75	866	6	2,780
AW2200	22	200	80	950	6	3,520
AW2400	24	224	90	1,253	-	3,810
AW2600	26	250	100	1,636	-	5,600
AW2700	27	250	100	1,764	-	5,900
AW3200	32	315	125	3,120	-	8,800
AW3600	36	355	140	4,440	-	11,700
AW4100	41	400	160	6,500	-	20,500
AW4600	46	440	180	9,220	-	26,400
AW5000	50	480	200	11,930	-	32,200

- Black Oxide Finish ( ~ 1000 )
- Cathodic Electrodeposition ( 1200 ~ )

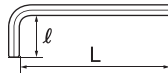

Code	⌀ inch	L mm	ℓ mm	Weight g		Price ¥
AWX0116	1/16	45	14	1	-	280
AWX0564	5/64	50	16	2	-	280
AWX0332	3/32	56	18	3	-	280
AWX0108	1/8	63	20	6	-	280
AWX0532	5/32	70	23	11	-	280
AWX0316	3/16	80	28	18	-	280
AWX0732	7/32	85	30	25	-	400
AWX0104	1/4	90	32	35	-	400
AWX0516	5/16	100	36	62	-	530
AWX0308	3/8	112	40	101	-	670
AWX0716	7/16	119	42	135	-	1,320
AWX0102	1/2	125	45	200	-	1,320

- Black Oxide Finish ( ~ 0104 )
- Cathodic Electrodeposition ( 0516 ~ )

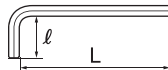

inch



TOOL SETS

SPANNERS

STRIKING FACE WRENCHES

HOOK SPANNERS

DX2000 TOOLS  
HEXAGON KEY WRENCHES

HEXAGON KEY WRENCHES

TORQUE WRENCHES

CROWFOOT WRENCHES

SOCKETS

OTHER TOOLS

# Hexagon Key Wrench

## Short type

**7Pcs.**

1.5 mm 2 mm 2.5 mm 3 mm 4 mm 5 mm 6 mm

Code	mm	Weight g	Box	Price ¥
AWS0770	AW-1.5, 2, 2.5, 3, 4, 5, 6	100	10	1,010

- Plastic Holder
- Blister pack 165 × 75 × 18mm

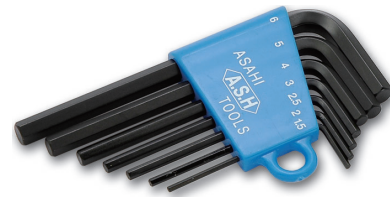

AWS0770

**8Pcs.**

1.5 mm 2 mm 2.5 mm 3 mm 4 mm 5 mm 6 mm 8 mm

Code	mm	Weight g	Box	Price ¥
AWS0880	AW-1.5, 2, 2.5, 3, 4, 5, 6, 8	152	5	1,130

- Plastic Holder
- Blister pack 165 × 90 × 18mm

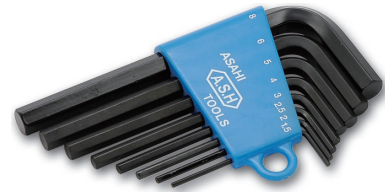

AWS0880

**8Pcs.**

2.5 mm 3 mm 4 mm 5 mm 6 mm 8 mm 10 mm 12 mm

Code	mm	Weight g	Box	Price ¥
AWS0810	AW-2.5, 3, 4, 5, 6, 8, 10, 12	420	10	1,530

- Tool Roll 200 × 120mm



AWS0810

**8Pcs.**

3 mm 4 mm 5 mm 6 mm 8 mm 10 mm 12 mm 14 mm

Code	mm	Weight g	Box	Price ¥
AWS0820	AW-3, 4, 5, 6, 8, 10, 12, 14	800	5	2,370

- Tool Roll 170 × 225mm



AWS0820

**9Pcs.**

1.5 mm 2 mm 2.5 mm 3 mm 4 mm 5 mm 6 mm 8 mm 10 mm

Code	mm	Weight g	Box	Price ¥
AWS0990	AW-1.5, 2, 2.5, 3, 4, 5, 6, 8, 10	280	10	1,420

- Plastic Holder
- Blister pack 190 × 90 × 27mm

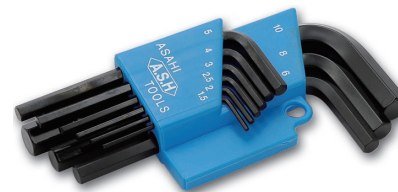

AWS0990

**8Pcs.**

1/8 3/16 7/32 1/4 5/16 3/8 7/16 1/2

Code	inch	Weight g	Box	Price ¥
AWS0830	AWX-1/8, 3/16, 7/32, 1/4, 5/16, 3/8, 7/16, 1/2	560	10	2,170

- Tool Roll 200 × 120mm

inch



AWS0830

TOOL SETS

SPANNERS

STRIKING FACE WRENCHES

HOOK SPANNERS

DX2000 TOOLS  
HEXAGON KEY WRENCHES

HEXAGON KEY WRENCHES

TORQUE WRENCHES

CROWFOOT WRENCHES

SOCKETS

OTHER TOOLS

# Hexagon Key Wrench

## Long type

Code	○ mm	L mm	ℓ mm	Weight g		Price ¥
AL0150	1.5	90	14	1.4	10	144
AL0200	2	100	16	3	10	144
AL0250	2.5	112	18	5.2	10	144
AL0300	3	126	20	8.8	10	154
AL0400	4	142	23	16	10	270
AL0500	5	160	28	32	10	360
AL0600	6	180	32	50	10	440
AL0800	8	200	36	100	10	630
AL1000	10	224	40	178	10	900
AL1200	12	250	45	290	4	1,410
AL1400	14	280	56	448	4	2,120
AL1700	17	320	63	754	4	2,660
AL1900	19	360	70	1,055	4	3,350

- Black Oxide Finish ( ~ 1000 )
- Cathodic Electrodeposition (1200 ~ )

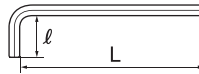

TOOL SETS  
SPANNERS  
STRIKING FACE WRENCHES  
HOOK SPANNERS  
DX2000 TOOLS  
HEXAGON KEY WRENCHES  
HEXAGON KEY WRENCHES  
TORQUE WRENCHES  
CROWFOOT WRENCHES  
SOCKETS  
OTHER TOOLS

**7Pcs.**

1.5 mm 2 mm 2.5 mm 3 mm 4 mm 5 mm 6 mm

Code	○ mm	Weight g		Price ¥
ALS0770	AL-1.5, 2, 2.5, 3, 4, 5, 6	150	10	1,870

- Plastic Holder
- Blister pack 240 × 75 × 18mm



ALS0770

**7Pcs.**

2.5 mm 3 mm 4 mm 5 mm 6 mm 8 mm 10 mm

Code	○ mm	Weight g		Price ¥
ALS0790	AL-2.5, 3, 4, 5, 6, 8, 10	425	5	3,000

- Plastic Holder
- Blister pack 290 × 90 × 27mm

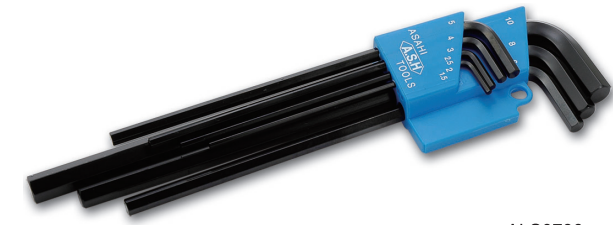

ALS0790

**9Pcs.**

1.5 mm 2 mm 2.5 mm 3 mm 4 mm 5 mm 6 mm 8 mm 10 mm

Code	○ mm	Weight g		Price ¥
ALS0990	AL-1.5, 2, 2.5, 3, 4, 5, 6, 8, 10	450	5	3,310

- Plastic Holder
- Blister pack 290 × 90 × 27mm

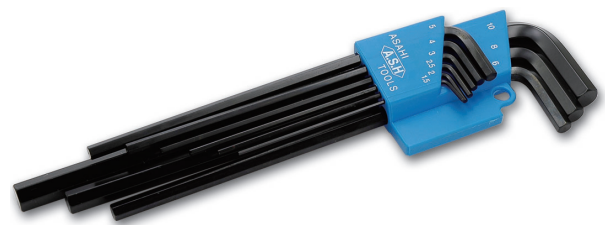

ALS0990



# Hexagon Key Wrench

## Micro / Long type

Code	Ø mm	L mm	ℓ mm	Weight g		Price ¥
EX0710	0.71	53	10.5	0.2	100	410
EX0890	0.89	60.5	12	0.4	100	410
EX1270	1.27	70	14	0.9	100	410

- Parkerizing
- Vinyl Pack



**6Pcs.**

0.71 mm 0.89 mm 1.27 mm 1.5 mm 2 mm 2.5 mm

Code	Ø mm	Weight g		Price ¥
MELS610	EX-0.71, 0.89, 1.27 AL-1.5, 2, 2.5	26	—	980

- Tool Roll 180 × 100mm



TOOL SETS

SPANNERS

STRIKING FACE WRENCHES

HOOK SPANNERS

DX2000 TOOLS  
HEXAGON KEY WRENCHES

HEXAGON KEY WRENCHES

TORQUE WRENCHES

CROWFOOT WRENCHES

SOCKETS

OTHER TOOLS

# Ballpoint Hexagon Key Wrench

## Standard type

Code	○ mm	L mm	ℓ mm	Weight g		Price ¥
AP0150	1.5	70	14	1.2	50	440
AP0200	2	75	16	2.4	50	440
AP0250	2.5	84	18	4	50	440
AP0300	3	95	20	6	50	460
AP0400	4	105	23	14	50	550
AP0500	5	120	28	24	10	600
AP0600	6	135	32	40	10	770
AP0800	8	150	36	80	10	960
AP1000	10	170	40	140	10	1,240
AP1200	12	185	45	220	10	1,830
AP1400	14	207	56	345	5	2,510
AP1700	17	220	63	550	5	3,220
AP1900	19	225	70	730	5	3,780
AP2200	22	246	80	1,060	-	5,200
AP2400	24	282	90	1,420	-	-
AP2700	27	325	100	2,100	-	-
AP3200	32	370	125	3,400	-	-
AP3600	36	455	140	5,200	-	-

- Black Oxide Finish ( ~ 1000 )
- Cathodic Electrodeposition ( 1200 ~ )
- Special Order ( 2400 ~ )

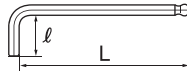

TOOL SETS

SPANNERS

STRIKING FACE WRENCHES

HOOK SPANNERS

DX2000 TOOLS

HEXAGON KEY WRENCHES

TORQUE WRENCHES

CROWFOOT WRENCHES

SOCKETS

OTHER TOOLS

**7Pcs.**

2.5 mm	3 mm	4 mm	5 mm	6 mm	8 mm	10 mm
--------	------	------	------	------	------	-------

Code	○ mm	Weight g		Price ¥
APS0710	AP-2.5, 3, 4, 5, 6, 8, 10	340	5	5,400

- Plastic Holder
- Blister pack 240 × 85 × 27mm



APS0710

**9Pcs.**

1.5 mm	2 mm	2.5 mm	3 mm	4 mm	5 mm	6 mm	8 mm	10 mm
--------	------	--------	------	------	------	------	------	-------

Code	○ mm	Weight g		Price ¥
APS0990	AP-1.5, 2, 2.5, 3, 4, 5, 6, 8, 10	360	5	6,200

- Plastic Holder
- Blister pack 240 × 85 × 27mm



APS0990

## Catcher Ball / Standard type

**7Pcs.**

1.5 mm	2 mm	2.5 mm	3 mm	4 mm	5 mm	6 mm
--------	------	--------	------	------	------	------

without Catcher Ball	with Catcher Ball
----------------------	-------------------

Code	○ mm	Weight g		Price ¥
APTS710	AP-1.5, 2, 2.5 APT-3, 4, 5, 6	100	10	4,390

- Black Oxide Finish
- Plastic Holder
- Blister pack 190 × 76 × 15mm



# Set On Ring

## Short type

**7Pcs.**

2 mm 2.5 mm 3 mm 4 mm 5 mm 6 mm 8 mm

Code	mm	Weight g	Box	Price ¥
ARS0710	2, 2.5, 3, 4, 5, 6, 8	160	10	970

- Black Oxide Finish
- Blister pack 190 × 80mm



ARS0710

**8Pcs.**

2 mm 2.5 mm 3 mm 4 mm 5 mm 6 mm 8 mm 10 mm

Code	mm	Weight g	Box	Price ¥
ARS0810	2, 2.5, 3, 4, 5, 6, 8, 10	270	10	1,180

- Black Oxide Finish
- Blister pack 190 × 80mm



ARS0810

**8Pcs.**

1.5 mm 2 mm 2.5 mm 3 mm 4 mm 5 mm 5.5 mm 6 mm

Code	mm	Weight g	Box	Price ¥
ARS0820	1.5, 2, 2.5, 3, 4, 5, 5.5, 6	120	10	920

- Black Oxide Finish
- Blister pack 190 × 80mm



ARS0820

**10Pcs.**

1.5 mm 2 mm 2.5 mm 3 mm 4 mm 5 mm 5.5 mm 6 mm 8 mm 10 mm

Code	mm	Weight g	Box	Price ¥
ARS1110	1.5, 2, 2.5, 3, 4, 5, 5.5, 6, 8, 10	290	10	1,260

- Black Oxide Finish
- Blister pack 190 × 80mm



ARS1110

**8Pcs.**

1/16 5/64 3/32 1/8 5/32 3/16 7/32 1/4

Code	inch	Weight g	Box	Price ¥
ARSE820	1/16, 5/64, 3/32, 1/8, 5/32, 3/16, 7/32, 1/4	120	10	1,040

- Black Oxide Finish
- Blister pack 185 × 80mm

inch



ARSE820

**10Pcs.**

1/16 5/64 3/32 1/8 5/32 3/16 7/32 1/4 5/16 3/8

Code	inch	Weight g	Box	Price ¥
ARSE110	1/16, 5/64, 3/32, 1/8, 5/32, 3/16, 7/32, 1/4, 5/16, 3/8	290	10	1,440

- Black Oxide Finish
- Blister pack 185 × 80mm

inch



ARSE110

TOOL SETS

SPANNERS

STRIKING FACE WRENCHES

HOOK SPANNERS

DX2000 TOOLS  
HEXAGON KEY WRENCHES

HEXAGON KEY WRENCHES

TORQUE WRENCHES

CROWFOOT WRENCHES

SOCKETS

OTHER TOOLS

# Convenient Holder

## Short type

**6Pcs.**

2.5 mm 3 mm 4 mm 5 mm 6 mm 8 mm

Code	mm	Weight g	Box	Price ¥
ANS0610	2.5, 3, 4, 5, 6, 8	245	10	2,510

- Black Oxide Finish
- Blister pack 190 × 65mm



ANS0610

**7Pcs.**

1.5 mm 2 mm 2.5 mm 3 mm 4 mm 5 mm 6 mm

Code	mm	Weight g	Box	Price ¥
ANS0710	1.5, 2, 2.5, 3, 4, 5, 6	145	10	2,410

- Black Oxide Finish
- Blister pack 140 × 50mm



ANS0710

**7Pcs.**

1/16 5/64 3/32 1/8 5/32 3/16 7/32

Code	inch	Weight g	Box	Price ¥
ANS0730	1/16, 5/64, 3/32, 1/8, 5/32, 3/16, 7/32	135	10	3,010

- Black Oxide Finish
- Blister pack 140 × 50mm

inch

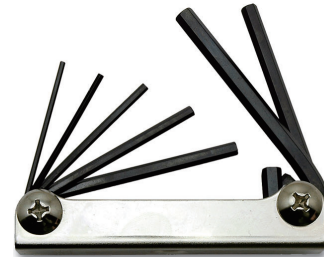

ANS0730

TOOL SETS

SPANNERS

STRIKING FACE WRENCHES

HOOK SPANNERS

HEXAGON KEY WRENCHES

HEXAGON KEY WRENCHES

TORQUE WRENCHES

CROWFOOT WRENCHES

SOCKETS

OTHER TOOLS

## T-Handled Separate type / Metric

Code	○ mm	L <sub>1</sub> mm	D <sub>1</sub> mm	L <sub>2</sub> mm	D <sub>2</sub> mm	L <sub>3</sub> mm	Weight g		Price ¥
VTH0300	3	125	9	120	6.4	210	35	10	3,020
VTH0400	4	180	11	120	8.4	220	69	10	3,330
VTH0500	5	180	11	120	8.4	220	70	10	3,470
VTH0600	6	210	16	140	10.4	245	135	5	3,800
VTH0800	8	250	19	175	11.6	280	200	5	4,370

• Nickel Chrome Plating

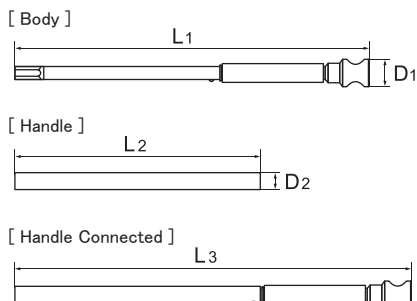

The handle can be stored in the body, so it takes up less storage space than existing T-shaped hexagon key wrenches, making it convenient to carry around.  
The quick-turn collar enables speedy work.  
The handle slides for use in either T or L configuration, depending on work requirements.

## Plastic Handle type / Metric

Code	○ mm	L mm	ℓ mm	W mm	Weight g		Price ¥
ATL0250	2.5	152	127	75	20	10	650
ATL0300	3	170	145	75	22	10	720
ATL0400	4	182	152	90	40	10	800
ATL0500	5	206	176	90	60	10	920
ATL0600	6	228	198	90	75	10	1,220

• Nickel Chrome Plating  
• Plastic Handle

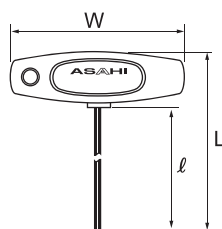

TOOL SETS

SPANNERS

STRIKING-FACE WRENCHES

HOOK SPANNERS

DX2000 TOOLS  
HEXAGON KEY WRENCHES

HEXAGON KEY WRENCHES

TORQUE WRENCHES

CROWFOOT WRENCHES

SOCKETS

OTHER TOOLS

# Hexlobe Short type

Code		L mm	ℓ mm	Weight g		Price ¥
ATX010	T10H	56	18	4	10	840
ATX015	T15H	63	20	8	10	910
ATX020	T20H	72	23	10	10	980
ATX025	T25H	80	28	16	10	1,090
ATX027	T27H	90	32	26	10	1,090
ATX030	T30H	100	36	29	10	1,150
ATX040	T40H	112	40	44	10	1,210

- Tamperproof Screw
- Electroless Nickel Plating
- Blister pack

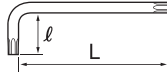

**7Pcs.** T10 T15 T20 T25 T27 T30 T40

Code		Weight g		Price ¥
ATXS710	ATX- T10H, T15H, T20H, T25H, T27H, T30H, T40H	150	10	7,100

- Plastic Holder
- Blister pack 190 × 90 × 25mm



# Holder Connect holer

Code	Hex Key Adjustables mm	H <sub>1</sub> mm	H <sub>2</sub> mm	D mm	L mm	Weight g		Price ¥
AI0152	1.5, 2	16	15	15	38	6.8	5	300
AI0253	2.5, 3	16	15	15	38	6.5	5	300
AI0400	4	16	15	15	38	6.5	5	300
AI0500	5	16	15	15	38	6.2	5	300
AI0600	6	16	15	15	38	5.8	5	300
AI0800	8	16	15	15	38	5	5	300
AI1000	10	16	15	15	38	3.6	5	300

- Vinyl Pack
- Polypropylene

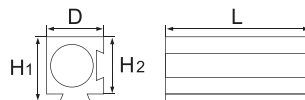

**7Pcs.** Code **AIS0710** Price **¥2,100**

Set Contains	
Connect Holder	AI- 1.5/2, 2.5/3, 4, 5, 6, 8, 10

- Weight 150g
- Vinyl Pack



# with the magnet

Code	Hex Key Adjustables mm	Weight g	Price ¥
AH1200	1.5 ~ 12mm	160	4,200

- Plastic
- Storage Box 140 × 75 × 50mm



# Torque Wrenches

## Open End Head



	LCS02	LCS04	LCS09	LCS18
Torque wrench insertion diameter	Φ10 mm	Φ12 mm	Φ15 mm	Φ18 mm
mm				
Width across flat				
7	●			
8	●	●		
9	●	●		
10	●	●		
11	●	●		
12	●	●	●	
13	●	●	●	
14	●	●	●	
17	●	●	●	●
19	●	●	●	●
21	●	●	●	●
22	●	●	●	●
24	●	●	●	●
27	●	●	●	●
30			●	●
32				●
36				●
41				●

## Ring Head



	LCR04	LCR09	LCR18
Torque wrench insertion diameter	Φ12 mm	Φ15 mm	Φ18 mm
mm			
Width across flat			
8	●		
10	●		
11	●		
12	●	●	
13	●	●	
14	●	●	
17	●	●	●
19	●	●	●
21		●	
22	●	●	●
24		●	●
27		●	●
30		●	●
32			●
36			●
41			●

## Hexagon Head



	LCX02	LCX04	LCX09	LCX18
Torque wrench insertion diameter	Φ10 mm	Φ12 mm	Φ15 mm	Φ18 mm
mm				
Width across flat				
2.5	●			
3	●			
4	●	●		
5		●	●	
6	●	●	●	●
8	●	●	●	●
10		●	●	●
12			●	●
14				●

## Hook Spanner Head



	LCK09	LCK18
Torque wrench insertion diameter	Φ15 mm	Φ18 mm
mm		
Bearing nut diameter		
30~32	●	
34~38	●	
40~42	●	
45~48	●	
50~55	●	
58~65		●
65~70		●
70~75		●
80~85		●
92~100		●

## Ratchet Head



	LQ3045	LQ3055	LQ4065	LQ4080
Torque wrench insertion diameter	Φ10 mm	Φ12 mm	Φ15 mm	Φ18 mm
Insertion angle mm	9.5		12.7	
	●	●	●	●



## Torque Wrench



	Φ10 mm	Φ12 mm	Φ15 mm	Φ18 mm
Replacement head insertion diameter				
Torque range N·m				
5~25	●			
10~50		●		
20~100			●	
40~200				●



## LCS Open End Head, Metric

### NEW Torque wrench with 10 mm insertion diameter



Code			effective length ℓ mm	B mm	h mm	H mm	L mm	Weight g		Price ¥
LCS0207	7	10	45	29	7	16	55	57	1	2,660
LCS0208	8	10	45	29	7	16	55	56	1	2,660
LCS0209	9	10	45	29	7	16	55	56	1	2,660
LCS0210	10	10	45	29	7	16	55	56	1	2,660
LCS0211	11	10	45	29	7	16	55	53	1	2,660
LCS0212	12	10	45	32	7	16	55.5	57	1	2,840
LCS0213	13	10	45	32	7	16	55.5	57	1	2,840
LCS0214	14	10	45	32	7	16	55.5	56	1	2,840
LCS0217	17	10	45	39	8	16	57.5	72	1	3,020
LCS0219	19	10	45	39	8	16	57.5	69	1	3,020
LCS0221	21	10	45	39	8	16	57.5	65	1	3,020
LCS0222	22	10	45	39	8	16	57.5	63	1	3,020
LCS0224	24	10	45	45	8	16	60	78	1	7,000
LCS0227	27	10	45	45	8	16	60	72	1	7,000





### Torque wrench with 12 mm insertion diameter

Code			effective length ℓ mm	B mm	h mm	H mm	L mm	Weight g		Price ¥
LCS0408	8	12	55	32	8	20	64	110	1	3,300
LCS0409	9	12	55	32	8	20	64	110	1	3,300
LCS0410	10	12	55	32	8	20	64	120	1	3,300
LCS0411	11	12	55	32	8	20	64	120	1	3,300
LCS0412	12	12	55	36	10	20	64	120	1	3,350
LCS0413	13	12	55	36	10	20	64	120	1	3,350
LCS0414	14	12	55	36	10	20	64	120	1	3,350
LCS0417	17	12	55	44	10	20	67	140	1	3,560
LCS0419	19	12	55	44	10	20	67	140	1	3,560
LCS0421	21	12	55	44	10	20	67	138	1	3,560
LCS0422	22	12	55	44	10	20	67	130	1	3,560
LCS0424	24	12	55	50	10	20	73	140	1	7,400
LCS0427	27	12	55	50	10	20	73	133	1	7,400

### Torque wrench with 15 mm insertion diameter

Code			effective length ℓ mm	B mm	h mm	H mm	L mm	Weight g		Price ¥
LCS0912	12	15	65	40	10	24	75	200	1	3,650
LCS0913	13	15	65	40	10	24	75	200	1	3,650
LCS0914	14	15	65	40	10	24	75	200	1	3,650
LCS0917	17	15	65	48	12	24	79	240	1	3,820
LCS0919	19	15	65	48	12	24	79	240	1	3,820
LCS0921	21	15	65	48	12	24	79	230	1	3,820
LCS0922	22	15	65	48	12	24	79	220	1	3,820
LCS0924	24	15	65	57	12	24	81	270	1	3,970
LCS0927	27	15	65	57	12	24	81	250	1	3,970
LCS0930	30	15	65	57	12	24	81	230	1	3,970

### Torque wrench with 18 mm insertion diameter

Code			effective length ℓ mm	B mm	h mm	H mm	L mm	Weight g		Price ¥
LCS1817	17	18	80	56	14	28	94	390	1	4,410
LCS1819	19	18	80	56	14	28	94	380	1	4,410
LCS1821	21	18	80	56	14	28	94	360	1	4,410
LCS1822	22	18	80	56	14	28	94	350	1	4,410
LCS1824	24	18	80	64	14	28	97	430	1	5,100
LCS1827	27	18	80	64	14	28	97	400	1	5,100
LCS1830	30	18	80	64	14	28	97	400	1	5,100
LCS1832	32	18	80	75	14	28	102	480	1	6,200
LCS1836	36	18	80	75	14	28	102	470	1	6,200
LCS1841	41	18	80	75	14	28	102	440	1	6,200

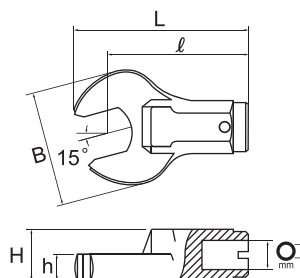

• Nickel Chrome Plating



## LCS Open End Head, Metric

25N·m

**9Pcs.**

Code **LCS1000** Price **¥40,800**

Set Contains

Torque Wrench	LC023N (Torque Range 5 ~ 25N·m)
Open End Head	LCS02- 7, 8, 9, 10, 12, 13, 14, 17

- Weight 1.7kg
- Tool Box 135 × 335 × 42mm

NEW



LCS1000

50N·m

**9Pcs.**

Code **LCS2000** Price **¥46,800**

Set Contains

Torque Wrench	LC045N (Torque Range 10 ~ 50N·m)
Open End Head	LCS04- 8, 10, 11, 12, 13, 14, 17, 19

- Weight 2.35kg
- Tool Box 135 × 335 × 42mm



LCS2000

100N·m

**9Pcs.**

Code **LCS3000** Price **¥51,800**

Set Contains

Torque Wrench	LC090N (Torque Range 20 ~ 100N·m)
Open End Head	LCS09- 12, 13, 14, 17, 19, 22, 24, 27

- Weight 3.8kg
- Tool Box 160 × 450 × 42mm



LCS3000

200N·m

**9Pcs.**

Code **LCS4000** Price **¥65,100**

Set Contains

Torque Wrench	LC180N (Torque Range 40 ~ 200N·m)
Open End Head	LCS18- 17, 19, 22, 24, 27, 30, 32, 36

- Weight 6.5kg
- Tool Box 180 × 520 × 63mm



LCS4000

TOOL SETS

SPANNERS

STRIKING FACE WRENCHES

HOOK SPANNERS

DX2000 TOOLS

HEXAGON KEY WRENCHES

TORQUE WRENCHES



CROWFOOT WRENCHES

SOCKETS

OTHER TOOLS



## LCR Ring Head, Metric

### Torque wrench with 12 mm insertion diameter



Code	 mm	 mm	$\ell$ effective length mm	D mm	h mm	H mm	L mm	Weight g		Price ¥
LCR0408	8	12	55	19	10	20	64.5	105	1	3,120
LCR0410	10	12	55	19	10	20	64.5	105	1	3,120
LCR0411	11	12	55	22	10	20	66	110	1	3,120
LCR0412	12	12	55	22	10	20	66	110	1	3,170
LCR0413	13	12	55	22	10	20	66	110	1	3,170
LCR0414	14	12	55	22	10	20	66	105	1	3,170
LCR0417	17	12	55	32	10	20	71	120	1	3,360
LCR0419	19	12	55	32	10	20	71	120	1	3,360
LCR0422	22	12	55	32	10	20	71	110	1	3,360



### Torque wrench with 15 mm insertion diameter

Code	 mm	 mm	$\ell$ effective length mm	D mm	h mm	H mm	L mm	Weight g		Price ¥
LCR0912	12	15	65	25	13	24	77.5	200	1	3,450
LCR0913	13	15	65	25	13	24	77.5	200	1	3,450
LCR0914	14	15	65	25	13	24	77.5	190	1	3,450
LCR0917	17	15	65	34	13	24	82	210	1	3,650
LCR0919	19	15	65	34	13	24	82	210	1	3,650
LCR0921	21	15	65	34	13	24	82	210	1	3,650
LCR0922	22	15	65	34	13	24	82	200	1	3,650
LCR0924	24	15	65	42	13	24	86	220	1	3,780
LCR0927	27	15	65	42	13	24	86	210	1	3,780
LCR0930	30	15	65	42	13	24	86	200	1	3,780

### Torque wrench with 18 mm insertion diameter

Code	 mm	 mm	$\ell$ effective length mm	D mm	h mm	H mm	L mm	Weight g		Price ¥
LCR1817	17	18	80	35	15	28	97.5	340	1	3,900
LCR1819	19	18	80	35	15	28	97.5	340	1	3,900
LCR1822	22	18	80	35	15	28	97.5	340	1	3,900
LCR1824	24	18	80	45	15	28	102.5	360	1	4,890
LCR1827	27	18	80	45	15	28	102.5	350	1	4,890
LCR1830	30	18	80	45	15	28	102.5	320	1	4,890
LCR1832	32	18	80	58	15	28	109	400	1	5,900
LCR1836	36	18	80	58	15	28	109	380	1	5,900
LCR1841	41	18	80	58	15	28	109	340	1	5,900

• Nickel Chrome Plating

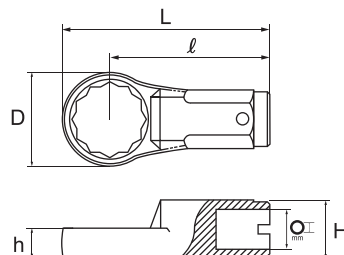

TOOL SETS

SPANNERS

STRIKING FACE WRENCHES

HOOK SPANNERS

DX2000 TOOLS  
HEXAGON KEY WRENCHES

HEXAGON KEY WRENCHES

TORQUE WRENCHES

CROWFOOT WRENCHES

SOCKETS

OTHER TOOLS

## LCR Ring Head, Metric

50N·m

**9Pcs.**

Code	<b>LCR2000</b>	Price	<b>¥44,900</b>
------	----------------	-------	----------------

Set Contains

Torque Wrench	LC045N (Torque Range 10 ~ 50N·m)
Ring Head	LCR04- 8, 10, 11, 12, 13, 14, 17, 19

- Weight 2.3kg
- Tool Box 135 × 335 × 42mm



LCR2000

100N·m

**9Pcs.**

Code	<b>LCR3000</b>	Price	<b>¥50,200</b>
------	----------------	-------	----------------

Set Contains

Torque Wrench	LC090N (Torque Range 20 ~ 100N·m)
Ring Head	LCR09- 12, 13, 14, 17, 19, 22, 24, 27

- Weight 3.55kg
- Tool Box 160 × 450 × 42mm



LCR3000

200N·m

**9Pcs.**

Code	<b>LCR4000</b>	Price	<b>¥63,500</b>
------	----------------	-------	----------------

Set Contains

Torque Wrench	LC180N (Torque Range 40 ~ 200N·m)
Ring Head	LCR18- 17, 19, 22, 24, 27, 30, 32, 36

- Weight 6.2kg
- Tool Box 180 × 520 × 63mm



LCR4000

TOOL SETS

SPANNERS

STRIKING FACE WRENCHES

HOOK SPANNERS

DX2000 TOOLS  
HEXAGON KEY WRENCHES

HEXAGON KEY WRENCHES

TORQUE WRENCHES

CROWFOOT WRENCHES

SOCKETS

OTHER TOOLS

## LCX Hexagon Head, Metric

### NEW Torque wrench with 10 mm insertion diameter

Code	$\varnothing$ mm	$\varnothing$ mm	$l$ effective length mm	$h$ mm	$H$ mm	$L$ mm	Weight g		Price ¥
LCX0225	2.5	10	45	27	16	46.3	56	1	3,900
LCX0203	3	10	45	29	16	46.5	55	1	3,900
LCX0204	4	10	45	35	16	47	55	1	4,000
LCX0205	5	10	45	38	16	47.5	55	1	4,100
LCX0206	6	10	45	43	16	48	56	1	4,100
LCX0208	8	10	45	48	16	49	60	1	4,200

### Torque wrench with 12 mm insertion diameter

Code	$\varnothing$ mm	$\varnothing$ mm	$l$ effective length mm	$h$ mm	$H$ mm	$L$ mm	Weight g		Price ¥
LCX0404	4	12	55	38	18	57	90	1	3,300
LCX0405	5	12	55	41.5	18	57.5	100	1	3,970
LCX0406	6	12	55	46	18	58	100	1	4,690
LCX0408	8	12	55	51	18	59	110	1	5,400
LCX0410	10	12	55	56	18	60	130	1	6,100

### Torque wrench with 15 mm insertion diameter

Code	$\varnothing$ mm	$\varnothing$ mm	$l$ effective length mm	$h$ mm	$H$ mm	$L$ mm	Weight g		Price ¥
LCX0905	5	15	65	44.5	23	67.5	170	1	4,130
LCX0906	6	15	65	49	23	68	170	1	4,860
LCX0908	8	15	65	54	23	69	180	1	5,700
LCX0910	10	15	65	59	23	70	200	1	6,400
LCX0912	12	15	65	65	23	71	225	1	7,100

### Torque wrench with 18 mm insertion diameter

Code	$\varnothing$ mm	$\varnothing$ mm	$l$ effective length mm	$h$ mm	$H$ mm	$L$ mm	Weight g		Price ¥
LCX1806	6	18	80	50.5	26	83	270	1	4,540
LCX1808	8	18	80	55.5	26	84	280	1	5,300
LCX1810	10	18	80	60.5	26	85	290	1	7,000
LCX1812	12	18	80	66.5	26	86	300	1	7,800
LCX1814	14	18	80	78.5	26	87	350	1	8,300

- Body : Nickel Chrome Plating
- Hex : Black Finishing

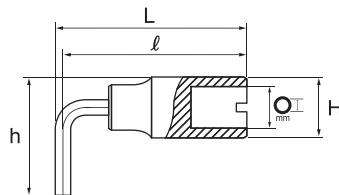

TOOL SETS

SPANNERS

STRIKING FACE WRENCHES

HOOK SPANNERS

DX2000 TOOLS  
HEXAGON KEY WRENCHES

HEXAGON KEY WRENCHES

TORQUE WRENCHES

CROWFOOT WRENCHES

SOCKETS

OTHER TOOLS

## LCX Hexagon Head, Metric

25N·m

**7Pcs.**

Code **LCX1000** Price **¥40,300**

Set Contains

Torque Wrench	LC023N (Torque Range 5 ~ 25N·m)
Hexagon Head	LCX02- 2.5, 3, 4, 5, 6, 8

- Weight 1.57kg
- Tool Box 135 × 335 × 42mm

**NEW**



LCX1000

50N·m

**6Pcs.**

Code **LCX2000** Price **¥40,600**

Set Contains

Torque Wrench	LC045N (Torque Range 10 ~ 50N·m)
Hexagon Head	LCX04- 4, 5, 6, 8, 10

- Weight 1.9kg
- Tool Box 135 × 335 × 42mm



LCX2000

100N·m

**6Pcs.**

Code **LCX3000** Price **¥46,400**

Set Contains

Torque Wrench	LC090N (Torque Range 20 ~ 100N·m)
Ring Head	LCX09- 5, 6, 8, 10, 12

- Weight 3.0kg
- Tool Box 160 × 450 × 42mm



LCX3000

200N·m

**6Pcs.**

Code **LCX4000** Price **¥55,100**

Set Contains

Torque Wrench	LC180N (Torque Range 40 ~ 200N·m)
Ring Head	LCX18- 6, 8, 10, 12, 14

- Weight 4.7kg
- Tool Box 180 × 520 × 63mm



LCX4000

TOOL SETS

SPANNERS

STRIKING FACE WRENCHES

HOOK SPANNERS

DX2000 TOOLS  
HEXAGON KEY WRENCHES

HEXAGON KEY WRENCHES

TORQUE WRENCHES



CROWFOOT WRENCHES

SOCKETS

OTHER TOOLS



# LCK Hook Spanner Head

## Torque wrench with 15 mm insertion diameter

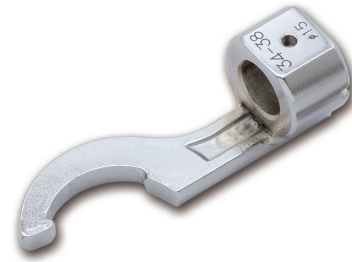
Code	 mm	 mm	$l$ effective length mm	C mm	h mm	H mm	L mm	Weight g		Price ¥
LCK0930	30~32	15	65	2.3	5	28	81	83	1	7,300
LCK0934	34~38	15	65	2.5	6	29	85	101	1	7,600
LCK0940	40~42	15	65	2.5	6	29	88	103	1	7,800
LCK0945	45~48	15	65	2.5	6.5	29.5	91	123	1	8,300
LCK0950	50~55	15	65	2.5	6.5	29.5	94	127	1	8,500



## Torque wrench with 18 mm insertion diameter

Code	 mm	 mm	$l$ effective length mm	C mm	h mm	H mm	L mm	Weight g		Price ¥
LCK1858	58~65	18	80	3	7.5	33.5	112	193	1	9,300
LCK1865	65~70	18	80	3	7.5	33.5	112	195	1	9,600
LCK1870	70~75	18	80	3.5	8	34	117	220	1	9,900
LCK1880	80~85	18	80	3.5	8.5	34.5	121	280	1	11,200
LCK1892	92~100	18	80	4	8.5	34.5	126	283	1	11,700

• Nickel Chrome Plating

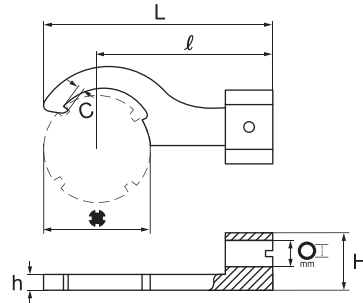

## 100N·m

**6Pcs.**

Code **LCK3000** Price **¥59,800**

Set Contains

Torque Wrench	LC090N (Torque Range 20 ~ 100N·m)
Hook Spanner Head	LCK09- 30, 34, 40, 45, 50

- Weight 2.7kg
- Tool Box 160 × 450 × 42mm



LCK3000

## 200N·m

**6Pcs.**

Code **LCK4000** Price **¥76,100**

Set Contains

Torque Wrench	LC180N (Torque Range 40 ~ 200N·m)
Hook Spanner Head	LCK18- 58, 65, 70, 80, 92

- Weight 4.3kg
- Tool Box 180 × 520 × 63mm



LCK4000

TOOL SETS

SPANNERS

STRIKING FACE WRENCHES

HOOK SPANNERS

DX2000 TOOLS  
HEXAGON KEY WRENCHES

HEXAGON KEY WRENCHES

TORQUE WRENCHES

CROWFOOT WRENCHES

SOCKETS

OTHER TOOLS

## LQ Ratchet Head

Code	mm	mm	effective length mm	b mm	h mm	H mm	L mm	Weight g	Price ¥
LQ3045	9.5	10	45	31	14	16	60	116	1 7,920
LQ3055	9.5	12	55	32	14	18	71	140	1 7,920
LQ4065	12.7	15	65	39	17	23	84.5	245	1 8,400
LQ4080	12.7	18	80	46	19	26	103	390	1 12,480

• Nickel Chrome Plating

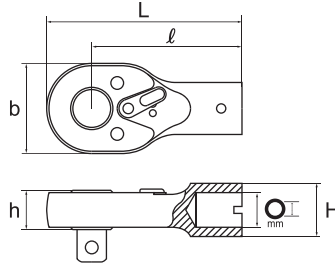

NEW

TOOL SETS

SPANNERS

STRIKING FACE WRENCHES

HOOK SPANNERS

DX2000 TOOL SETS

HEXAGON KEY WRENCHES

TORQUE WRENCHES

CROWFOOT WRENCHES

SOCKETS

OTHER TOOLS

### 25N·m

**11Pcs.**

Code	<b>LCV1000</b>	Price	<b>¥35,200</b>
------	----------------	-------	----------------

Set Contains

Torque Wrench	LC023N (Torque Range 5 ~ 25N·m)
Ratchet Head	LQ3045
Socket (12pt.)	VS3- 7, 8, 9, 10, 12, 13, 14, 17
Extension Bar	VE0375 (75mm)

- Weight 1.65kg
- Tool Box 135 × 335 × 42mm



LCV1000

### 50N·m

**11Pcs.**

Code	<b>LCV2000</b>	Price	<b>¥36,300</b>
------	----------------	-------	----------------

Set Contains

Torque Wrench	LC045N (Torque Range 10 ~ 50N·m)
Ratchet Head	LQ3055
Socket (12pt.)	VS3- 8, 10, 11, 12, 13, 14, 17, 19
Extension Bar	VE0375 (75mm)

- Weight 2.1kg
- Tool Box 135 × 335 × 42mm



LCV2000

### 100N·m

**11Pcs.**

Code	<b>LCV3000</b>	Price	<b>¥39,900</b>
------	----------------	-------	----------------

Set Contains

Torque Wrench	LC090N (Torque Range 20 ~ 100N·m)
Ratchet Head	LQ4065
Socket (12pt.)	VS4- 12, 13, 14, 17, 19, 22, 24, 27
Extension Bar	VE0415 (150mm)

- Weight 3.2kg
- Tool Box 160 × 450 × 42mm



LCV3000

### 200N·m

**11Pcs.**

Code	<b>LCV4000</b>	Price	<b>¥47,300</b>
------	----------------	-------	----------------

Set Contains

Torque Wrench	LC180N (Torque Range 40 ~ 200N·m)
Ratchet Head	LQ4080
Socket (12pt.)	VS4- 14, 17, 19, 22, 24, 27, 30, 32
Extension Bar	VE0425 (250mm)

- Weight 5.2kg
- Tool Box 180 × 520 × 63mm



LCV4000

## LC Torque Wrench, Pre-set Type, with Tool Carrier for Insert Tool

Code	Torque Range N·m	Ø mm	effective length mm	L mm	Weight g		Price ¥
<b>NEW</b> LC023N	5~25	10	190	208	200	1	16,900
LC045N	10~50	12	215	238	380	1	17,900
LC090N	20~100	15	320	331	600	1	19,400
LC180N	40~200	18	445	455	1,350	1	23,400

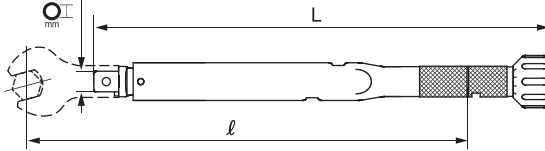

### Features of th Product

- When the pre-set torque is reached, a click can be felt and heard.
- Accuracy  $\pm 3\%$
- Interchangeable heads are available with various adjustables.

## LCQ Torque Wrench with Ratchet Head, with Tool Carrier for Insert Tool

Code	Torque Range N·m	Ø mm	Ø mm	effective length mm	b mm	h mm	L mm	Weight g		Price ¥
<b>NEW</b> LCQ023N	5~25	10	9.5	190	31	14	255	315	1	25,280
LCQ045N	10~50	12	9.5	215	32	14	293	520	1	26,280
LCQ090N	20~100	15	12.7	320	39	17	398	845	1	28,620
LCQ180N	40~200	18	12.7	445	46	19	536	1,740	1	35,400

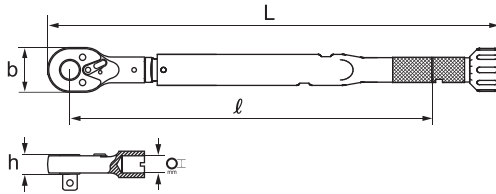

### Features of th Product

- When the pre-set torque is reached, a click can be felt and heard.
- Accuracy  $\pm 3\%$
- Interchangeable heads are available with various adjustables.



# Crowfoot Wrench, Spanner Type

## Crowfoot Wrench, Spanner Type



	VC2	VC3	VC4
Insertion angle mm	6.3	9.5	12.7
mm Width across flat			
5.5	●		
6	●		
7	●		
8	●	●	
9		●	
10	●	●	
12	●	●	
13	●	●	
14		●	
15		●	
16		●	
17		●	●
19		●	●
21		●	
22		●	●
24		●	●
26		●	
27		●	●
29		●	
30		●	●
32		●	●
36			●
41			●
46			●
50			●
55			●
60			●

## Long Crowfoot Wrench, Spanner Type



	VCL3	VCL4
Insertion angle mm	9.5	12.7
mm Width across flat		
10	●	
12	●	
13	●	
14	●	
17	●	
19	●	●
22		●
24		●
27		●
30		●
32		●
36		●

# 1/4" (6.3mm) - Drive

## VC2 Crowfoot Wrench, Spanner Type

Code	mm	B mm	b mm	H mm	L mm	effective length ℓ mm	Weight g		Price ¥
VC2005	5.5	16	12.7	6	22	12	10	-	1,950
VC2006	6	16	12.7	6	22	12	10	-	1,950
VC2007	7	17	12.7	6	24	13	11	-	1,980
VC2008	8	17	12.7	6	25	14	11	-	2,080
VC2010	10	19	12.7	6	27	15	12	-	2,260
VC2012	12	22.5	12.7	6	29	16	14.5	-	2,370
VC2013	13	24	12.7	6	30	16	15.5	-	2,520

• Nickel Chrome Plating

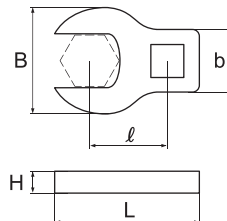

Hand Tool



**9Pcs.**

Code **VCS2090**

Price **¥23,400**

Set Contains

Crowfoot Wrench	VC2- 5, 6, 7, 8, 10, 12, 13
Extension Bar	VE0215
Ratchet Handle	VR0215

- Weight 580g
- Tool Box 110 × 200 × 35mm



TOOL SETS

SPANNERS

STRIKING FACE WRENCHES

HOOK SPANNERS

DX2000 TOOLS  
HEXAGON KEY WRENCHES

HEXAGON KEY WRENCHES

TORQUE WRENCHES

CROWFOOT WRENCHES

SOCKETS

OTHER TOOLS



Please do not use the product of this mark with the power tool including the impact wrench.

**ASAHI**  
TOOLS

# 3/8" (9.5mm) - Drive

## VC3 Crowfoot Wrench, Spanner Type

Code	mm	B mm	b mm	H mm	h mm	L mm	effective length ℓ mm	Weight g	Price ¥
VC3008	8	21	17	10	6.3	31.6	15.6	21	- 1,890
VC3009	9	21	17	10	6.3	31.4	16.2	20	- 1,890
VC3010	10	21	17	10	6.3	31.2	16.8	20	- 1,890
VC3012	12	24	17	10	6.3	33.7	17.9	25	- 1,890
VC3013	13	24	17	10	6.3	32.7	18.5	25	- 1,890
VC3014	14	24	17	10	6.3	32.6	19.1	25	- 1,890
VC3015	15	28.8	17	10	6.3	37.5	20.2	30	- 2,010
VC3016	16	28.8	17	10	6.3	37.4	20.7	29	- 2,010
VC3017	17	28.8	17	10	6.3	37.4	21.3	27	- 2,010
VC3019	19	38	19	10	6.3	42.6	24	42	- 2,150
VC3021	21	38	19	10	6.3	41.6	25.1	40	- 2,150
VC3022	22	41	19	10	6.3	46	25.7	48	- 2,970
VC3024	24	41	19	10	6.3	44	26.8	45	- 2,970
VC3026	26	46	19	11.5	9.5	50	28	80	- 4,580
VC3027	27	46	19	11.5	9.5	50	28.6	70	- 4,580
VC3029	29	50	19	11.5	9.5	51	29.7	75	- 5,500
VC3030	30	50	19	11.5	9.5	51	30.3	75	- 5,500
VC3032	32	50	19	11.5	9.5	50	31.5	72	- 5,500

• Nickel Chrome Plating

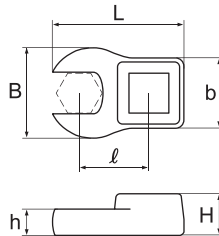

<b>11Pcs.</b>	Code	<b>VCS3110</b>	Price	<b>¥22,100</b>
Set Contains				
Crowfoot Wrench	VC3- 8, 10, 12, 13, 14, 16, 17, 19, 21, 22, 24			
Holder	275mm			

- Weight 380g
- Storage Box 130 × 350 × 55mm

NEW



VCS3110

<b>13Pcs.</b>	Code	<b>VCS3131</b>	Price	<b>¥31,200</b>
Set Contains				
Crowfoot Wrench	VC3- 8, 10, 12, 13, 14, 16, 17, 19, 21, 22, 24			
Extension Bar	VEB330 Flexible Type			
Ratchet Handle	VRL3180 <b>Revowave</b> ®			

- Weight 1.8kg
- Tool Box 130 × 350 × 55mm



VCS3131

<b>18Pcs.</b>	Code	<b>VCS3180</b>	Price	<b>¥51,000</b>
Set Contains				
Crowfoot Wrench	VC3- 8, 9, 10, 12, 13, 14, 15, 16, 17, 19, 21, 22, 24, 26, 27, 29, 30, 32			
Holder	420mm			

- Weight 970g
- Storage Box 115 × 440 × 30mm





VCS3180



Please do not use the product of this mark with the power tool including the impact wrench.

# 3/8" (9.5mm) - Drive

## VCL3 Long Crowfoot Wrench, Spanner Type

Code	 mm	B mm	b mm	H mm	L mm	effective length ℓ mm	Weight g		Price ¥
VCL3010	10	22	17	8	50	64.5	55	-	2,390
VCL3012	12	25	17	8	50	66	56.5	-	2,540
VCL3013	13	26	17	8	50	65.5	57.5	-	2,540
VCL3014	14	28	17	8	50	66	58.5	-	2,620
VCL3017	17	32	19	8	50	67.5	67.5	-	2,650
VCL3019	19	38	21	8	50	68.5	81.5	-	2,730

• Nickel Chrome Plating

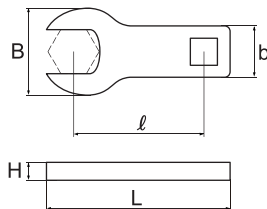

NEW



**6Pcs.**

Code **VCLS360**

Price **¥16,600**

Set Contains

Crowfoot Wrench VCL3- 10, 12, 13, 14, 17, 19

- Weight 424g
- Storage Box 85 × 235 × 25mm

NEW



TOOL SETS

SPANNERS

STRIKING FACE WRENCHES

HOOK SPANNERS

DX2000 TOOLS  
HEXAGON KEY WRENCHES

HEXAGON KEY WRENCHES

TORQUE WRENCHES

CROWFOOT WRENCHES

SOCKETS

OTHER TOOLS



Please do not use the product of this mark with the power tool including the impact wrench.

**ASAHI**  
TOOLS

# 1/2" (12.7mm) - Drive

## VC4 Crowfoot Wrench, Spanner Type

Code	mm	B mm	b mm	H mm	L mm	effective length ℓ mm	Weight g		Price ¥
VC4017	17	32	22	12	55	33	80	-	4,620
VC4019	19	36	22	12	57	35	90	-	4,620
VC4022	22	42	24	12	61	38	113	-	4,620
VC4024	24	46	26	12	64	38	128	-	4,860
VC4027	27	50	27	12	67.5	40	145	-	5,100
VC4030	30	54	28	12	73	43	164	-	5,500
VC4032	32	56	28	12	73	43	165	-	5,700
VC4036	36	62	30	12	77	45.5	191	-	5,800
VC4041	41	68	32	12	86	50	224	-	6,300
VC4046	46	74	32	12	91	52	254	-	10,100
VC4050	50	79	34	12	94	54	274	-	10,400
VC4055	55	84	34	12	101.5	57	314	-	11,400
VC4060	60	89	34	12	103.5	59	320	-	11,700

• Nickel Chrome Plating

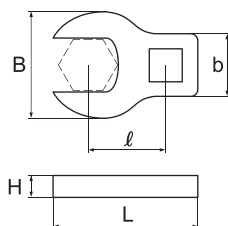

<b>8Pcs.</b>	Code	<b>VCS4080</b>	Price	<b>¥39,000</b>
Set Contains				
Crowfoot Wrench	VC4- 17, 19, 22, 24, 27, 30, 32, 36			
Holder	275mm			

- Weight 1.2kg
- Storage Box 290 × 130 × 30mm



VCS4080

<b>10Pcs.</b>	Code	<b>VCS4100</b>	Price	<b>¥50,100</b>
Set Contains				
Crowfoot Wrench	VC4- 17, 19, 22, 24, 27, 30, 32, 36			
Extension Bar	VEB438 Flexible Type			
Ratchet Handle	VRL4250 <b>Revo wave</b>			

- Weight 3.4kg
- Tool Box 150 × 450 × 55mm



VCS4100

<b>13Pcs.</b>	Code	<b>VCS4130</b>	Price	<b>¥87,700</b>
Set Contains				
Crowfoot Wrench	VC4- 17, 19, 22, 24, 27, 30, 32, 36, 41, 46, 50, 55, 60			
Holder	220mm / 275mm			

- Weight 2.7kg
- Storage Box 200 × 510 × 50mm



VCS4130

TOOL SETS

SPANNERS

STRIKING FACE WRENCHES

HOOK SPANNERS

DX2000 TOOLS

HEXAGON KEY WRENCHES

HEXAGON KEY WRENCHES

TORQUE WRENCHES

CROWFOOT WRENCHES

SOCKETS

OTHER TOOLS



Please do not use the product of this mark with the power tool including the impact wrench.

**ASAHI**  
TOOLS

# 1/2" (12.7mm) - Drive

## VCL4 Long Crowfoot Wrench, Spanner Type

Code	mm	B mm	b mm	H mm	L mm	effective length ℓ mm	Weight g		Price ¥
VCL4019	19	36	22	12	86	65	147	-	4,850
VCL4022	22	42	24	12	87	65	169	-	4,850
VCL4024	24	46	26	12	89.5	65	190	-	5,100
VCL4027	27	50	28	12	91.5	65	207	-	5,400
VCL4030	30	54	28	12	93.5	65	218	-	5,800
VCL4032	32	56	28	12	93	65	218	-	6,000
VCL4036	36	62	30	12	95	65	243	-	6,100

• Nickel Chrome Plating

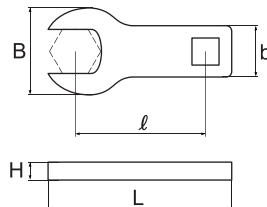

NEW



<b>7Pcs.</b>	Code	<b>VCLS470</b>	Price	<b>¥39,300</b>
Set Contains				
Crowfoot Wrench	VCL4- 19, 22, 24, 27, 30, 32, 36			

- Weight 1.5kg
- Storage Box 115 × 440 × 30mm

NEW



TOOL SETS

SPANNERS

STRIKING FACE WRENCHES

HOOK SPANNERS

DX2000 TOOLS  
HEXAGON KEY WRENCHES

HEXAGON KEY WRENCHES

TORQUE WRENCHES

CROWFOOT WRENCHES

SOCKETS

OTHER TOOLS



Please do not use the product of this mark with the power tool including the impact wrench.

**ASAHI**  
TOOLS

# Sockets

**Socket**



	VS2	VS3	VK3	VS4	VJR4	VK4	VF4	VS6
Insertion angle mm	6.3	9.5		12.7				19.0
Shape	6point	12point	12point Deep	12point	6point	12point Deep	12point Spline	12point
Width across flat mm								
4	●							
4.5	●							
5	●							
5.5	●							
6	●	●						
7	●	●						
8	●	●	●	●	●	●		
9	●	●	●	●	●	●		
10	●	●	●	●	●	●	●	
11	●	●	●	●	●	●		
12	●	●	●	●	●	●	●	
13	●	●	●	●	●	●	●	
14		●	●	●	●	●	●	
15		●	●	●	●	●	●	
16		●	●	●	●	●		
17		●	●	●	●	●	●	
18		●	●	●	●	●		
19		●	●	●	●	●	●	●
20		●	●	●	●	●		
21		●	●	●	●	●	●	●
22		●	●	●	●	●	●	●
23		●	●	●	●	●		
24				●	●	●	●	●
25						●		
26				●	●	●		●
27				●	●	●		●
28						●		
29				●		●		●
30				●	●	●		●
31						●		
32				●	●	●		●
35								●
36								●
38								●
41								●
46								●
50								●
54								●
55								●

**Hex Bit Socket**



	VX2	VX3	VX4
Insertion angle mm	6.3	9.5	12.7
Width across flat mm			
3	●	●	
4	●	●	●
5	●	●	●
6	●	●	●
8	●	●	●
10	●	●	●
12			●
14			●
17			●

# 1/4" (6.3mm) - Drive

## SD2 Socket Wrench Set

**34Pcs.**

Code **SD2340**

Price **¥11,000**

Set Contains

Socket (12point)	VS2- 4, 4.5, 5, 5.5, 6, 7, 8, 9, 10, 11, 13
Hexagon Socket	VX2- 3, 4, 5, 6, 8, 10
Driver Bit Socket	VD2- $\ominus$ 4, $\ominus$ 5.5, $\ominus$ 7 VD2- $\oplus$ No.1, $\oplus$ No.2, $\oplus$ No.3, $\oplus$ No.4
Ratchet Handle	VR0200
Extension Bar	50mm, 100mm
Other Tools	Universal Joint, Sliding T-Handle, Driver Handle, Spin Disk
Hexagon Key Wrench	1.5, 2, 2.5

- Weight 900g
- Tool Box 110×200×35mm



TOOL SETS

SPANNERS

STRIKING FACE WRENCHES

HOOK SPANNERS

DX2000 TOOLS

HEXAGON KEY WRENCHES

TORQUE WRENCHES

CROWFOOT WRENCHES

SOCKETS

OTHER TOOLS

## VS2 Socket, Metric

Code	$\odot$ mm	D <sub>1</sub> mm	D <sub>2</sub> mm	h mm	L mm	Weight g		Price ¥
VS2040	4	6.7	11.8	6	25	12	10	660
VS2045	4.5	7.4	11.8	8	25	12	10	660
VS2050	5	8	11.8	9	25	12	10	660
VS2055	5.5	8.7	11.8	9	25	12	10	660
VS2060	6	9.3	11.8	9	25	12	10	660
VS2070	7	10.5	11.8	9	25	13	10	660
VS2080	8	11.8	11.8	10	25	15	10	660
VS2090	9	12.6	12.6	10	25	15	10	660
VS2100	10	14	14	10	25	16	10	690
VS2110	11	15.8	15.8	10	25	22	10	690
VS2120	12	17	17	10	25	25	10	690
VS2130	13	17	17	10	25	25	10	740

- Nickel Chrome Plating

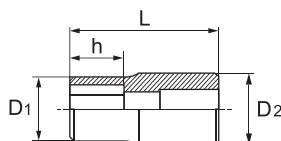

## VX2 Hexagon Socket, Metric

Code	$\odot$ mm	D mm	ℓ mm	L mm	Weight g		Price ¥
VX2003	3	12	6	25	11	-	710
VX2004	4	12	6.5	25	12	-	710
VX2005	5	12	7.5	25	13	-	710
VX2006	6	12	8	25	14	-	710
VX2008	8	12	9	25	15	-	710
VX2010	10	12	10	25	18	-	710

- Body : Nickel Chrome Plating
- Hex : Black Oxide Finish

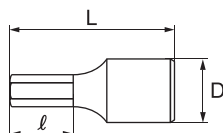



# 1/4" (6.3mm) - Drive

## VD2 Driver Bit Socket

Code	⊕ ⊖	D <sub>mm</sub>	L <sub>mm</sub>	Weight <sub>g</sub>		Price ¥
VD2001	⊕ No.1	12	25	10	-	750
VD2002	⊕ No.2	12	25	11	-	750
VD2003	⊕ No.3	12	25	12	-	750
VD2004	⊕ No.4	12	25	13	-	750
VD2040	⊖ 4	12	25	9	-	750
VD2055	⊖ 5.5	12	25	10	-	750
VD2070	⊖ 7	12	25	11	-	750

• Nickel Chrome Plating

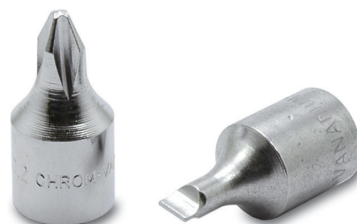
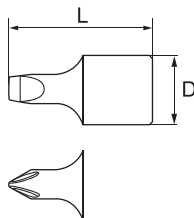

TOOL SETS

SPANNERS

STRIKING FACE WRENCHES

HOOK SPANNERS

DX2000 TOOLS  
HEXAGON KEY WRENCHES

HEXAGON KEY WRENCHES

TORQUE WRENCHES

CROWFOOT WRENCHES

SOCKETS

OTHER TOOLS

## VR2 Ratchet Handle

Code	D <sub>mm</sub>	T <sub>mm</sub>	L <sub>mm</sub>	Ratcheting Angle	Weight <sub>g</sub>		Price ¥
VR0211	24.5	18	125	9°	110	1	4,520

- Square Drive : Parkerizing
- Body : Nickel Chrome Plating
- Rubber grip

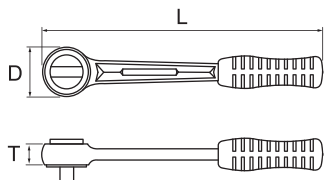

## VE2 Extension Bar

Code	D <sub>mm</sub>	L <sub>mm</sub>	Weight <sub>g</sub>		Price ¥
VE0275	12.5	75	35	-	1,010
VE0215	12.5	150	70	-	1,160

• Nickel Chrome Plating

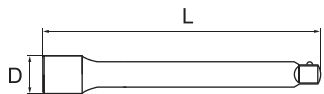

## VH2 Spinner Handle

Code	D <sub>mm</sub>	L <sub>mm</sub>	Weight <sub>g</sub>		Price ¥
VH0215	13	140	85	-	2,210

- Nickel Chrome Plating
- Insert a crossbar to the hole of the spinner handle to utilize as a T-handed wrench.

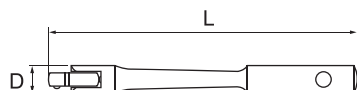

## 1/4" (6.3mm) - Drive

### VT2 Sliding T-Handle

Code	H mm	d mm	L mm	Weight g		Price ¥
VT0211	24	6	115	70	-	1,710

- Nickel Chrome Plating
- Adjust a position of a square drive for quick turning and final tightening.

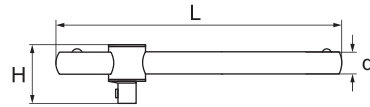

Hand Tool



### VU2 Universal Joint

Code	D mm	L mm	Weight g		Price ¥
VU0200	14	35	70	-	2,550

- Nickel Chrome Plating

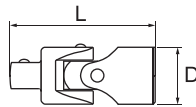

Hand Tool

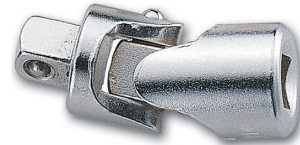

### VG2 Driver Handle

Code	L mm	Weight g		Price ¥
VG0214	150	65	-	1,460

- Plastic grip

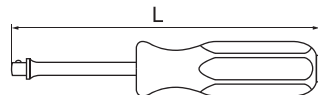

Hand Tool



### VB2 Cross Bar

Code	D mm	L mm	Weight g		Price ¥
VB0212	6	125	30	-	270

- Nickel Chrome Plating
- Insert a crossbar through the hole of the spinner handle and utilize as a T-handled wrench.

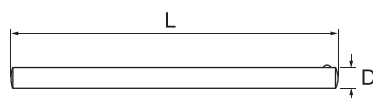

Hand Tool



TOOL SETS

SPANNERS

STRIKING FACE WRENCHES

HOOK SPANNERS

DX2000 TOOLS  
HEXAGON KEY WRENCHES

HEXAGON KEY WRENCHES

TORQUE WRENCHES

CROWFOOT WRENCHES

SOCKETS

OTHER TOOLS



Please do not use the product of this mark with the power tool including the impact wrench.

**ASAHI**  
TOOLS

# 3/8" (9.5mm) - Drive

## VO3 Socket Wrench Set

**19Pcs.**

Code **VO3121**

小売価格 **¥23,800**

Set Contains

Socket (12point)	VS3- 6, 7, 8, 9, 10, 11, 12, 13, 14, 17, 19, 21, 22
Ratchet Handle	LVR3180 <b>LIGHTTOOL®</b>
Extension Bar	VE0375 (75mm), 0315 (150mm)
Universal Joint	VU0300
Spinner Handle	VH0319 (228mm)
Speed Disk	VQ0300

- Weight 1870g
- Tool Box 105 × 290 × 60mm



VO3121

**19Pcs.**

Code **VO3122**

小売価格 **¥24,000**

Set Contains

Socket (12point)	VS3- 6, 7, 8, 9, 10, 11, 12, 13, 14, 17, 19, 21, 22
Ratchet Handle	VRL3180 <b>Revowave®</b>
Extension Bar	VE0375 (75mm), 0315 (150mm)
Universal Joint	VU0300
Spinner Handle	VH0319 (228mm)
Speed Disk	VQ0300

- Weight 1950g
- Tool Box 105 × 290 × 60mm



VO3122

TOOL SETS

SPANNERS

STRIKING FACE WRENCHES

HOOK SPANNERS

DX2000 TOOLS  
HEXAGON KEY WRENCHES

HEXAGON KEY WRENCHES

TORQUE WRENCHES

CROWFOOT WRENCHES

SOCKETS

OTHER TOOLS





Please do not use the product of this mark with the power tool including the impact wrench.

**ASAHI**  
TOOLS

# 3/8" (9.5mm) - Drive

## VS3 Socket, Metric

Code	 mm	D <sub>1</sub> mm	D <sub>2</sub> mm	h mm	L mm	Weight g		Price ¥
VS3060	6	10	17	9	26	22	10	660
VS3070	7	11	17	9	26	22	10	660
VS3080	8	12	18	9	26	20	10	700
VS3090	9	13	18	9	26	20	10	700
VS3100	10	14.5	18	9	26	20	10	700
VS3110	11	16	18	10	26	20	10	710
VS3120	12	18	18	10	26	20	10	710
VS3130	13	19	19	11	26	30	10	710
VS3140	14	20	20	11	26	40	10	710
VS3150	15	21	21	12	26	50	10	770
VS3160	16	23	23	12	26	50	10	770
VS3170	17	24	24	12	26	54	10	770
VS3180	18	25	25	12	26	55	10	800
VS3190	19	26	26	12	26	60	10	800
VS3210	21	29	29	13	28	80	10	840
VS3220	22	30	27	13	28	74	10	950
VS3230	23	32	32	14	30	90	10	950

• Nickel Chrome Plating

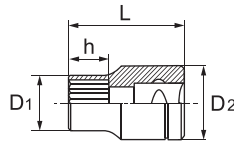



Hand Tool

12point



## VK3 Deep Socket, Metric

Code	 mm	D <sub>1</sub> mm	D <sub>2</sub> mm	h mm	L mm	Weight g		Price ¥
VK3080	8	12	17	8	55	59	-	1,500
VK3090	9	13.5	17.5	9	55	54	-	1,500
VK3100	10	14.5	18	11	55	55	-	1,500
VK3110	11	15.5	18	12	55	58	-	1,500
VK3120	12	17	18	13	55	59	-	1,500
VK3130	13	18.5	18.5	13	55	60	-	1,540
VK3140	14	19.5	18.5	14	55	62	-	1,540
VK3150	15	21	19	15	55	67	-	1,490
VK3160	16	22	19.5	15	55	71	-	1,490
VK3170	17	23	20	15	55	71	-	1,610
VK3180	18	24.5	20.5	16	55	82	-	1,810
VK3190	19	26	21	16	55	89	-	1,810
VK3200	20	27	21.5	17	55	96	-	1,810
VK3210	21	28.5	22	18	65	112	-	1,810
VK3220	22	30	22.5	18	65	113	-	1,930
VK3230	23	31	23	18	65	114	-	1,930

• Nickel Chrome Plating

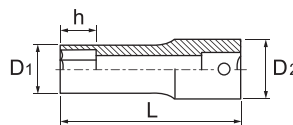

Hand Tool

12point



TOOL SETS  
SPANNERS  
STRIKING FACE WRENCHES  
HOOK SPANNERS  
DX2000 TOOLS  
HEXAGON KEY WRENCHES  
HEXAGON KEY WRENCHES  
TORQUE WRENCHES  
CROWFOOT WRENCHES  
SOCKETS  
OTHER TOOLS



Please do not use the product of this mark with the power tool including the impact wrench.

## 3/8" (9.5mm) - Drive

### VX3 Hex Bit Socket, Metric

Code	mm	D mm	ℓ mm	L mm	Weight g	Price ¥
VX3003	3	18	22	48	30	810
VX3004	4	18	22	48	35	810
VX3005	5	17	26	52	31	830
VX3006	6	17	26	52	38	870
VX3008	8	19	26	52	50	940
VX3010	10	19	26	52	59	1,040

- Body : Nickel Chrome Plating
- Hex : Black Oxide Finish ( ~ 3006 )  
Decorative Chromium Plating(3008 ~ )

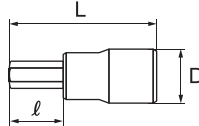

### VD3 Driver Bit Socket

Code	+	-	D mm	L mm	Weight g	Price ¥
VD3001	+	No.1	18	48	40	1,070
VD3002	+	No.2	18	48	40	1,070
VD3005	-	5	18	48	35	1,100
VD3006	-	6	18	48	35	1,100

- Body : Nickel Chrome Plating
- Bit : Parkerizing

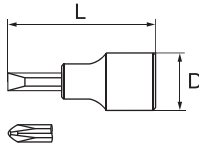

### VR3 Ratchet Handle

Code	D mm	T mm	L mm	Ratcheting Angle	Weight g	Price ¥
VR0319	34	15	204	9°	330	5,000

- Square Drive : Cathodic Electrodeposition
- Body : Nickel Chrome Plating

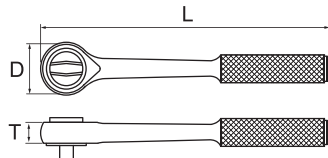

Please do not use the product of this mark with the power tool including the impact wrench.

## 3/8" (9.5mm) - Drive

### LVR3 Ratchet Handle

Code	D mm	T mm	L mm	Ratcheting Angle	Weight g		Price ¥
LVR3180	30	12.5	180	5°	178	1	5,500

- Square Drive : Parkerizing
- Body : Nickel Chrome Plating

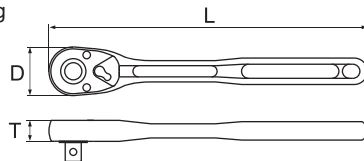

**LIGHTTOOL®**



TOOL SETS

SPANNERS

STRIKING FACE WRENCHES

HOOK SPANNERS

DX2000 TOOLS  
HEXAGON KEY WRENCHES

HEXAGON KEY WRENCHES

TORQUE WRENCHES

CROWFOOT WRENCHES

SOCKETS

OTHER TOOLS

### VRL3 Ratchet Handle

Code	D mm	T mm	L mm	Ratcheting Angle	Weight g		Price ¥
VRL3180	30	12.5	183	5°	270	1	5,700

- Square Drive : Parkerizing
- Body : Nickel Chrome Plating

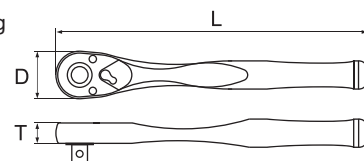

**Revowave®**



### VQ3 Speed Disk

Code	D mm	T mm	Weight g		Price ¥
VQ0300	35	3	11	-	280

- Nickel Chrome Plating

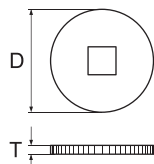

Attach it to a ratchet handle for fast-turning work.



Please do not use the product of this mark with the power tool including the impact wrench.

**ASAHI**  
TOOLS

## 3/8" (9.5mm) - Drive

### VE3 Extension Bar

Code	D mm	L mm	Weight g		Price ¥
VE0375	18	75	80	-	1,160
VE0315	18	150	150	-	1,400

- Nickel Chrome Plating

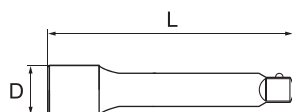

Hand Tool



### VEB3 Wobble Extension Bar

Code	D mm	L mm	Weight g		Price ¥
VEB330	19	300	210	-	3,430

- Nickel Chrome Plating



Hand Tool



Designed to be used at an angle off-axis to the screw by 10 degrees.

### VH3 Spinner Handle

Code	D mm	B mm	L mm	Weight g		Price ¥
VH0319	22	14.5	228	250	-	3,780

- Nickel Chrome Plating

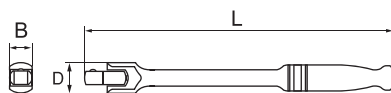

Hand Tool



TOOL SETS

SPANNERS

STRIKING FACE WRENCHES

HOOK SPANNERS

DX2000 TOOLS  
HEXAGON KEY WRENCHES

HEXAGON KEY WRENCHES

TORQUE WRENCHES

CROWFOOT WRENCHES

SOCKETS

OTHER TOOLS



Please do not use the product of this mark with the power tool including the impact wrench.

**ASAHI**  
TOOLS

## 3/8" (9.5mm) - Drive

### VT3 Sliding T-Handle

Code	H mm	d mm	L mm	Weight g		Price ¥
VT0320	32	11	200	190	-	1,950

• Nickel Chrome Plating

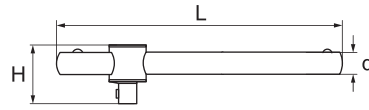

Adjust a position of a square drive for quick turning and final tightening.

### VTL3 T-Shape Speed Handle, Separate Type

Code	L <sub>1</sub> mm	D <sub>1</sub> mm	L <sub>2</sub> mm	D <sub>2</sub> mm	L <sub>3</sub> mm	Weight g		Price ¥
VTL0300	269	22	200	16	340	450	2	4,900

• Nickel Chrome Plating

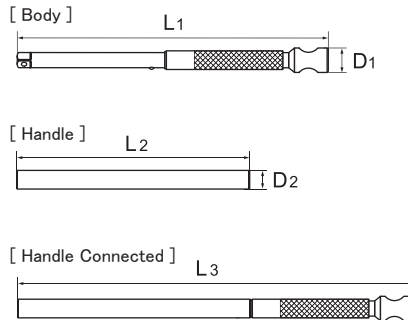

The handle can be stored in the body, so it takes up less storage space than existing T-shaped handles, making it convenient to carry around.  
The quick-turn collar enables speedy work.  
The handle slides for use in either T or L configuration, depending on work requirements.

### VU3 Universal Joint

Code	D mm	L mm	Weight g		Price ¥
VU0300	18	54	100	-	2,640

• Nickel Chrome Plating

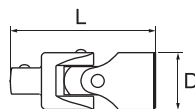

Please do not use the product of this mark with the power tool including the impact wrench.



## 3/8" (9.5mm) - Drive

### VA3 Adaptor

Code	$\frac{mm}{mm} \times \frac{mm}{mm}$	D mm	L mm	Weight g		Price ¥
VA3020	9.5 × 6.3	18	26	30	-	1,540
VA3040	9.5 × 12.7	17	30	33	-	1,540

- Nickel Chrome Plating

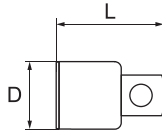

Hand Tool



### VP3 Plug Socket

Code	$\frac{mm}{mm}$	A mm	D mm	L mm	Weight g		Price ¥
VP0321	21	19	28	70	120	-	1,820

- Nickel Chrome Plating
- The internal rubber surface secures plugs firmly.

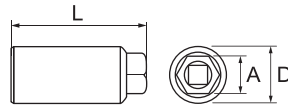

Hand Tool



12point



### VB3 Cross Bar

Code	D mm	L mm	Weight g		Price ¥
VB0315	8	150	60	-	440

- Nickel Chrome Plating

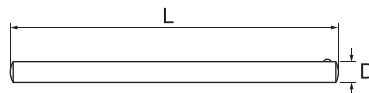

Hand Tool



TOOL SETS

SPANNERS

STRIKING FACE WRENCHES

HOOK SPANNERS

DX2000 TOOLS  
HEXAGON KEY WRENCHES

HEXAGON KEY WRENCHES

TORQUE WRENCHES

CROWFOOT WRENCHES

SOCKETS

OTHER TOOLS



Please do not use the product of this mark with the power tool including the impact wrench.

**ASAHI**  
TOOLS

# 1/2" (12.7mm) - Drive

## VO4 Socket Wrench Set, 12point, Metric

**13Pcs.**

Code **VO4100** Price **¥22,000**

Set Contains	
Socket (12point)	VS4- 10, 12, 13, 14, 15, 17, 19, 21, 23, 26
Ratchet Handle	LVR4252 <b>LIGHTTOOL®</b>
Sliding T-Handle	VT0425
Extension Bar	VE0415 (150mm)

- Weight 2.5kg
- Tool Box 105 × 290 × 60mm



VO4100

**13Pcs.**

Code **VO4101** Price **¥22,000**

Set Contains	
Socket (12point)	VS4- 8, 10, 11, 12, 13, 14, 17, 19, 22, 24
Ratchet Handle	LVR4252 <b>LIGHTTOOL®</b>
Sliding T-Handle	VT0425
Extension Bar	VE0415 (150mm)

- Weight 2.5kg
- Tool Box 105 × 290 × 60mm



VO4101

**17Pcs.**

Code **VO4131** Price **¥27,400**

Set Contains	
Socket (12point)	VS4- 8, 10, 11, 12, 13, 14, 17, 19, 21, 22, 24, 26, 27
Ratchet Handle	LVR4252 <b>LIGHTTOOL®</b>
Spinner Handle	VH0430 (300mm)
Extension Bar	VE0415 (150mm)
Cross Bar	VB0425 (250mm)

- Weight 3.6kg
- Tool Box 130 × 350 × 55mm



VO4131

**20Pcs.**

Code **VO4150** Price **¥37,400**

Set Contains	
Socket (12point)	VS4- 9, 10, 12, 13, 14, 15, 16, 17, 18, 19, 21, 23, 26, 29, 32
Ratchet Handle	LVR4252 <b>LIGHTTOOL®</b>
Spinner Handle	VH0438 (380mm)
Extension Bar	VE0415 (150mm)
Sliding T-Handle	VT0425
Cross Bar	VB0425 (250mm)

- Weight 4.7kg
- Tool Box 150 × 450 × 55mm



VO4150

TOOL SETS

SPANNERS

STRIKING FACE WRENCHES

HOOK SPANNERS

DX2000 TOOLS  
HEXAGON KEY WRENCHES

HEXAGON KEY WRENCHES

TORQUE WRENCHES

CROWFOOT WRENCHES

SOCKETS

OTHER TOOLS



Please do not use the product of this mark with the power tool including the impact wrench.

# 1/2" (12.7mm) - Drive

## VO4 Socket Wrench Set, 12point, Metric

**20Pcs.**

Code **VO4151** Price **¥38,000**

Set Contains

Socket (12point)	VS4- 10, 11, 12, 13, 14, 17, 19, 21, 22, 23, 24, 26, 27, 30, 32
Ratchet Handle	LVR4252 <b>LIGHTTOOL®</b>
Spinner Handle	VH0438 (380mm)
Extension Bar	VE0415 (150mm)
Sliding T-Handle	VT0425
Cross Bar	VB0425 (250mm)

- Weight 4.8kg
- Tool Box 150 × 450 × 55mm



VO4151

**14Pcs.**

Code **VO4200** Price **¥22,700**

Set Contains

Socket (12point)	VS4- 10, 12, 13, 14, 15, 17, 19, 21, 23, 26
Ratchet Handle	VRL4250 <b>Revowave®</b>
Sliding T-Handle	VT0425
Extension Bar	VE0415 (150mm)
Speed Disk	VQ0400

- Weight 2.6kg
- Tool Box 105 × 290 × 60mm



VO4200

**14Pcs.**

Code **VO4201** Price **¥22,700**

Set Contains

Socket (12point)	VS4- 8, 10, 11, 12, 13, 14, 17, 19, 22, 24
Ratchet Handle	VRL4250 <b>Revowave®</b>
Sliding T-Handle	VT0425
Extension Bar	VE0415 (150mm)
Speed Disk	VQ0400

- Weight 2.6kg
- Tool Box 105 × 290 × 60mm



VO4201

**18Pcs.**

Code **VO4231** Price **¥28,100**

Set Contains

Socket (12point)	VS4- 8, 10, 11, 12, 13, 14, 17, 19, 21, 22, 24, 26, 27
Ratchet Handle	VRL4250 <b>Revowave®</b>
Spinner Handle	VH0430 (300mm)
Extension Bar	VE0415 (150mm)
Cross Bar	VB0425 (250mm)
Speed Disk	VQ0400

- Weight 3.7kg
- Tool Box 130 × 350 × 55mm



VO4231

TOOL SETS

SPANNERS

STRIKING FACE WRENCHES

HOOK SPANNERS

DX2000 TOOLS  
HEXAGON KEY WRENCHES

HEXAGON KEY WRENCHES

TORQUE WRENCHES

CROWFOOT WRENCHES

SOCKETS

OTHER TOOLS



Please do not use the product of this mark with the power tool including the impact wrench.

**ASAHI**  
TOOLS

## 1/2" (12.7mm) - Drive

### VO4 Socket Wrench Set, 12point, Metric

**21Pcs.**

 Code **VO4250** Price **¥38,000**

Set Contains

Socket (12point)	VS4- 9, 10, 12, 13, 14, 15, 16, 17, 18, 19, 21, 23, 26, 29, 32
Ratchet Handle	VRL4250 <b>Revo wave</b>
Spinner Handle	VH0438 (380mm)
Extension Bar	VE0415 (150mm)
Sliding T-Handle	VT0425
Cross Bar	VB0425 (250mm)
Speed Disk	VQ0400

- Weight 4.8kg
- Tool Box 150 × 450 × 55mm



VO4250

**21Pcs.**

 Code **VO4251** Price **¥38,600**

Set Contains

Socket (12point)	VS4- 10, 11, 12, 13, 14, 17, 19, 21, 22, 23, 24, 26, 27, 30, 32
Ratchet Handle	VRL4250 <b>Revo wave</b>
Spinner Handle	VH0438 (380mm)
Extension Bar	VE0415 (150mm)
Sliding T-Handle	VT0425
Cross Bar	VB0425 (250mm)
Speed Disk	VQ0400

- Weight 4.9kg
- Tool Box 150 × 450 × 55mm



VO4251

### VJS4 Socket Wrench Set, 6point, Metric

**13Pcs.**

 Code **VJS4100** Price **¥21,800**

Set Contains

Socket (6point)	VJR4-10, 12, 13, 14, 15, 17, 19, 21, 23, 26
Ratchet Handle	LVR4252 <b>LIGHTOOL</b>
Sliding T-Handle	VT0425
Extension Bar	VE0415 (150mm)

- Weight 2.5kg
- Tool Box 105 × 290 × 60mm



VJS4100

**13Pcs.**

 Code **VJS4101** Price **¥21,800**

Set Contains

Socket (6point)	VJR4-8, 10, 11, 12, 13, 14, 17, 19, 22, 24
Ratchet Handle	LVR4252 <b>LIGHTOOL</b>
Sliding T-Handle	VT0425
Extension Bar	VE0415 (150mm)

- Weight 2.5kg
- Tool Box 105 × 290 × 60mm



VJS4101



Please do not use the product of this mark with the power tool including the impact wrench.

**ASAHI TOOLS**

TOOL SETS

SPANNERS

STRIKING FACE WRENCHES

HOOK SPANNERS

HEXAGON KEY WRENCHES

HEXAGON KEY WRENCHES

TORQUE WRENCHES

CROWFOOT WRENCHES

SOCKETS

OTHER TOOLS

# 1/2" (12.7mm) - Drive

## VJS4 Socket Wrench Set, 6point, Metric

**17Pcs.**

Code **VJS4131** Price **¥28,300**

Set Contains	
Socket (6point)	VJR4-8, 10, 11, 12, 13, 14, 17, 19, 21, 22, 24, 26, 27
Ratchet Handle	LVR4252 <b>LIGHTOOL</b> <sup>®</sup>
Spinner Handle	VH0430 (300mm)
Extension Bar	VE0415 (150mm)
Cross Bar	VB0425 (250mm)

- Weight 3.6kg
- Tool Box 130 × 350 × 55mm



VJS4131

**20Pcs.**

Code **VJS4151** Price **¥37,700**

Set Contains	
Socket (6point)	VJR4-10, 11, 12, 13, 14, 17, 19, 21, 22, 23, 24, 26, 27, 30, 32
Ratchet Handle	LVR4252 <b>LIGHTOOL</b> <sup>®</sup>
Spinner Handle	VH0438 (380mm)
Extension Bar	VE0415 (150mm)
Sliding T-Handle	VT0425
Cross Bar	VB0425 (250mm)

- Weight 4.8kg
- Tool Box 150 × 450 × 55mm



VJS4151

**14Pcs.**

Code **VJS4200** Price **¥22,400**

Set Contains	
Socket (6point)	VJR4-10, 12, 13, 14, 15, 17, 19, 21, 23, 26
Ratchet Handle	VRL4250 <b>Revo wave</b> <sup>®</sup>
Sliding T-Handle	VT0425
Extension Bar	VE0415 (150mm)
Speed Disk	VQ0400

- Weight 2.6kg
- Tool Box 105 × 290 × 60mm



VJS4200

**14Pcs.**

Code **VJS4201** Price **¥22,400**

Set Contains	
Socket (6point)	VJR4-8, 10, 11, 12, 13, 14, 17, 19, 22, 24
Ratchet Handle	VRL4250 <b>Revo wave</b> <sup>®</sup>
Sliding T-Handle	VT0425
Extension Bar	VE0415 (150mm)
Speed Disk	VQ0400

- Weight 2.6kg
- Tool Box 105 × 290 × 60mm



VJS4201

TOOL SETS

SPANNERS

STRIKING FACE WRENCHES

HOOK SPANNERS

DX2000 TOOLS  
HEXAGON KEY WRENCHES

HEXAGON KEY WRENCHES

TORQUE WRENCHES

CROWFOOT WRENCHES

SOCKETS

OTHER TOOLS



Please do not use the product of this mark with the power tool including the impact wrench.

## 1/2" (12.7mm) - Drive

### VJS4 Socket Wrench Set, 6point, Metric

**18Pcs.**

Code **VJS4231** Price **¥29,000**

Set Contains

Socket (6point)	VJR4-8, 10, 11, 12, 13, 14, 17, 19, 21, 22, 24, 26, 27
Ratchet Handle	VRL4250 <b>Revowave</b> <sup>®</sup>
Spinner Handle	VH0430 (300mm)
Extension Bar	VE0415 (150mm)
Cross Bar	VB0425 (250mm)
Speed Disk	VQ0400

- Weight 3.7kg
- Tool Box 130 × 350 × 55mm



VJS4231

**21Pcs.**

Code **VJS4251** Price **¥38,300**

Set Contains

Socket (6point)	VJR4-10, 11, 12, 13, 14, 17, 19, 21, 22, 23, 24, 26, 27, 30, 32
Ratchet Handle	VRL4250 <b>Revowave</b> <sup>®</sup>
Spinner Handle	VH0438 (380mm)
Extension Bar	VE0415 (150mm)
Sliding T-Handle	VT0425
Cross Bar	VB0425 (250mm)
Speed Disk	VQ0400

- Weight 4.9kg
- Tool Box 150 × 450 × 55mm



VJS4251

### VFS4 Socket Wrench Set, Spline

**13Pcs.**

Code **VFS4100** Price **¥19,600**

Set Contains

Hybrid Socket	VF4- 10, 12, 13, 14, 15, 17, 19, 21, 22, 24
Ratchet Handle	LVR4252 <b>LIGHTTOOL</b> <sup>®</sup>
Extension Bar	VE0415(150mm)
Sliding T-Handle	VT0425(250mm)

- Weight 2.3kg
- Tool Box 105 × 290 × 60mm



### VX4 Hex Bit Socket Wrench Set, Metric

**12Pcs.**

Code **VX4000** Price **¥22,500**

Set Contains

Hexagon Socket	VX4- 4, 5, 6, 8, 10, 12, 14, 17
Driver Bit Socket	VD4- ⊖6, ⊕No.2
Ratchet Handle	LVR4252 <b>LIGHTTOOL</b> <sup>®</sup>
Extension Bar	VE0415 (150mm)

- Weight 2.4kg
- Tool Box 132 × 364 × 45mm



TOOL SETS

SPANNERS

STRIKING FACE WRENCHES

HOOK SPANNERS

DX2000 TOOLS  
HEXAGON KEY WRENCHES

HEXAGON KEY WRENCHES

TORQUE WRENCHES

CROWFOOT WRENCHES

SOCKETS

OTHER TOOLS





Please do not use the product of this mark with the power tool including the impact wrench.

**ASAHI**  
TOOLS

# 1/2" (12.7mm) - Drive

## VS4 Socket, Metric



Code	 mm	D <sub>1</sub> mm	D <sub>2</sub> mm	h mm	L mm	Weight g		Price ¥
VS4080	8	13	22	12.5	36	42	10	790
VS4090	9	13.6	23	11	37	42	10	790
VS4100	10	15	22	11	36	42	10	790
VS4110	11	16	23	7	37	44	10	790
VS4120	12	17	22	11	36	50	10	790
VS4130	13	19	22	12	36	47	10	790
VS4140	14	20	23	10	37	46	10	790
VS4150	15	21	22	10	38	54	10	820
VS4160	16	23	23	15	37	60	10	820
VS4170	17	24	23	13.5	38	63	10	820
VS4180	18	25	24	13	38	64	10	860
VS4190	19	26	24	15	38	69	10	860
VS4210	21	28	26	17	38	81	5	910
VS4220	22	30	26	17	38	85	5	910
VS4230	23	32	26	15	38	99	5	1,000
VS4240	24	32	27	16	38	93	5	1,000
VS4260	26	34	28	18	38	110	5	1,050
VS4270	27	36	29	18	42	127	5	1,140
VS4290	29	38.5	28	23	44	180	5	1,330
VS4300	30	40	33	21	44	183	5	1,420
VS4320	32	42	35	21	44	201	5	1,600

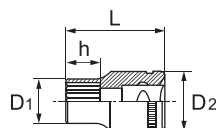

• Nickel Chrome Plating



## VJR4 Socket, Metric

Code	 mm	D <sub>1</sub> mm	D <sub>2</sub> mm	h mm	L mm	Weight g		Price ¥
VJR4080	8	12	23	11	37	50	-	800
VJR4100	10	15	22	13	36	43	-	800
VJR4110	11	16.5	22	12	36	45	-	800
VJR4120	12	17	22	12.5	36	45	-	800
VJR4130	13	19	22	11	36	48	-	800
VJR4140	14	20	22	13	36	60	-	800
VJR4150	15	21	23	14	37	60	-	860
VJR4160	16	22.5	24	14	38	66	-	860
VJR4170	17	24	23	14	38	66	-	860
VJR4180	18	25	23	14	38	61	-	860
VJR4190	19	26	24	18	38	68	-	860
VJR4210	21	28	26	17	38	84	-	950
VJR4220	22	30	26	16	38	93	-	950
VJR4230	23	32	26	15	38	103	-	1,010
VJR4240	24	32	27	17	38	99	-	1,040
VJR4260	26	34	28	18	38	105	-	1,090
VJR4270	27	36	29	19	44	150	-	1,210
VJR4300	30	40	33	21	44	192	-	1,530
VJR4320	32	42	35	21	44	214	-	1,670

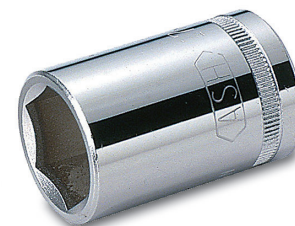

• Nickel Chrome Plating

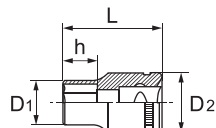

TOOL SETS

SPANNERS

STRIKING FACE WRENCHES

HOOK SPANNERS

DX2000 TOOLS  
HEXAGON KEY WRENCHES

HEXAGON KEY WRENCHES

TORQUE WRENCHES

GROW FOOT WRENCHES

SOCKETS

OTHER TOOLS



Please do not use the product of this mark with the power tool including the impact wrench.

# Hybrid Socket

Due to the unique spline shape interior, a socket is compatible with metric or inch-sized bolts, hexalobe screws, and square bolts.

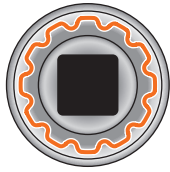
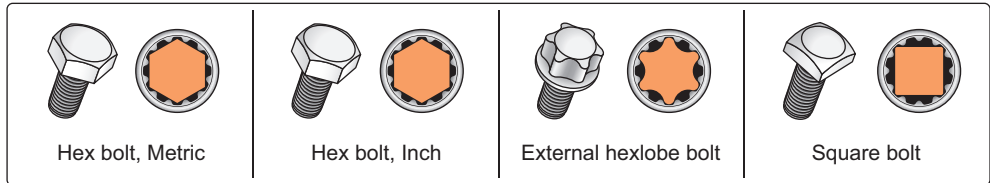

Unique spline shape

Bolt Compatibility Table

Code	VF4100	VF4120	VF4130	VF4140	VF4150	VF4170	VF4190	VF4210	VF4220	VF4240
ボルト										
mm	10	12	13	14	15	17	19	21	22	24
inch			1/2				3/4	13/16	7/8	15/16
E type							E24		E28	
mm					13				19	

(For reference)

## VF4 Socket, Metric

Code	mm	D1 mm	D2 mm	h mm	L mm	Weight g		Price ¥
VF4100	10	15.5	22	14	38	48	-	550
VF4120	12	18	22	14	38	51	-	550
VF4130	13	19.2	22	14	38	51	-	550
VF4140	14	20.5	22	14	38	51	-	550
VF4150	15	22	21	14	38	50	-	550
VF4170	17	24	22	14	38	58	-	560
VF4190	19	26	24	15	38	66	-	630
VF4210	21	29	26	15	38	86	-	740
VF4220	22	30	26	15	38	88	-	740
VF4240	24	32	28	15	38	102	-	830

• Nickel Chrome Plating

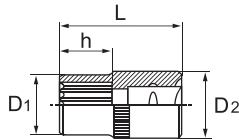



Please do not use the product of this mark with the power tool including the impact wrench.



# 1/2" (12.7mm) - Drive

## VK4 Deep Socket, Metric



Code	 mm	D <sub>1</sub> mm	D <sub>2</sub> mm	h mm	L mm	Weight g		Price ¥
VK4080	8	12.5	21	10	80	82	-	2,020
VK4090	9	13.5	21	10.5	80	86	-	2,020
VK4100	10	15	21	11.5	80	94	-	2,090
VK4110	11	16	21	13	80	93	-	2,090
VK4120	12	17.5	22	14.5	80	112	-	2,090
VK4130	13	19	22	16	80	117	-	2,150
VK4140	14	20	22	17	80	123	-	2,200
VK4150	15	21	22	18	80	130	-	2,290
VK4160	16	22.5	22.5	19	80	136	-	2,290
VK4170	17	24	23	21	80	143	-	2,300
VK4180	18	25	24	23	80	152	-	2,350
VK4190	19	26.5	24	23	80	152	-	2,350
VK4200	20	27.5	25	25	80	153	-	2,450
VK4210	21	28.5	25	25	80	167	-	2,450
VK4220	22	30	26	27	80	162	-	2,690
VK4230	23	31	26	27	80	195	-	2,810
VK4240	24	32.5	27	29	80	178	-	2,890
VK4250	25	33.5	27	29	80	200	-	3,060
VK4260	26	35	28	29	80	200	-	3,170
VK4270	27	36	28	30	80	212	-	3,290
VK4280	28	37	29	30	80	212	-	3,600
VK4290	29	38.5	30	30	80	253	-	3,600
VK4300	30	39.5	31	30	80	258	-	3,710
VK4310	31	41	32	30	80	278	-	3,990
VK4320	32	42	33	30	80	293	-	3,990

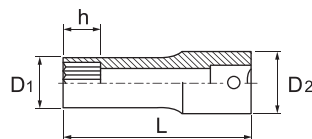

• Nickel Chrome Plating



## VX4 Hex Bit Socket, Metric

Code	 mm	D mm	ℓ mm	L mm	Weight g		Price ¥
VX4004	4	23	22	60	60	10	1,020
VX4005	5	23	22	60	65	10	1,020
VX4006	6	23	22	60	75	10	1,020
VX4008	8	23	22	60	90	10	1,070
VX4010	10	23	22	60	110	10	1,130
VX4012	12	24	22	60	120	10	1,170
VX4014	14	24	22	60	130	10	1,210
VX4017	17	28	30	70	200	10	1,360



• Body : Nickel Chrome Plating  
 • Hex : Black Oxide Finish ( ~ 4006 )  
 Cathodic Electrodeposition (4008 ~ )

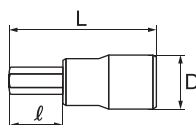

# 1/2" (12.7mm) - Drive

## VD4 Driver Bit Socket

Code	⊕ ⊖	D mm	L mm	Weight g		Price ¥
VD4002	⊕ No.2	23	60	65	-	1,170
VD4003	⊕ No.3	23	60	85	-	1,290
VD4004	⊕ No.4	23	60	90	-	1,380
VD4006	⊖ 6	23	60	75	-	1,290
VD4008	⊖ 8	23	60	95	-	1,380
VD4010	⊖ 10	23	60	95	-	1,430

- Body : Nickel Chrome Plating
- Bit : Parkerizing

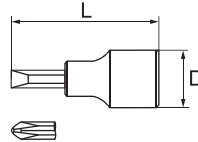

## LVR4 Ratchet Handle

Code	D mm	T mm	L mm	Ratcheting Angle	Weight g		Price ¥
LVR4252	38.5	16.5	250	5°	400	1	6,400

- Square Drive : Parkerizing
- Body : Nickel Chrome Plating

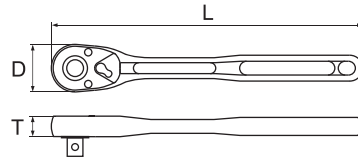

LIGHTTOOL®



## VRL4 Ratchet Handle

Code	D mm	T mm	L mm	Ratcheting Angle	Weight g		Price ¥
VRL4250	38.5	16.5	250	5°	520	1	6,800

- Square Drive : Parkerizing
- Body : Nickel Chrome Plating

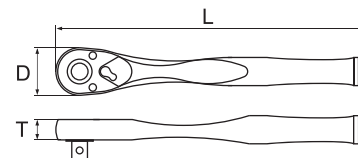

Revowave®



## VQ4 Speed Disk

Code	D mm	T mm	Weight g		Price ¥
VQ0400	41	3	17	-	310

- Nickel Chrome Plating

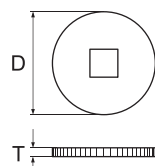

Attach it to a ratchet handle for fast-turning work.

## 1/2" (12.7mm) - Drive

### VE4 Extension Bar

Code	D mm	L mm	Weight g		Price ¥
VE0475	24	75	140	-	1,600
VE0415	24	150	260	5	1,730
VE0425	24	250	400	2	2,510

- Nickel Chrome Plating

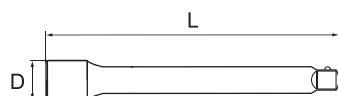

### VEB4 Wobble Extension Bar

Code	D mm	L mm	Weight g		Price ¥
VEB438	24	380	440	2	4,410

- Nickel Chrome Plating



Designed to be used at an angle off-axis to the screw by 10 degrees.

### VH4 Spinner Handle

Code	D mm	B mm	L mm	Weight g		Price ¥
VH0430	31	21	300	630	2	4,740
VH0438	31	21	380	770	2	5,300

- Nickel Chrome Plating

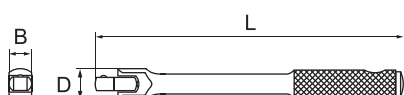

Insert a crossbar to the hole of the spinner handle to utilize as a T-handled wrench.

### VT4 Sliding T-Handle

Code	H mm	d mm	L mm	Weight g		Price ¥
VT0425	42	14	250	380	2	2,500

- Nickel Chrome Plating

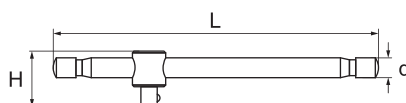

Adjust a position of a square drive for quick turning and final tightening.

TOOL SETS

SPANNERS

STRIKING FACE WRENCHES

HOOK SPANNERS

DX2000 TOOLS  
HEXAGON KEY WRENCHES

HEXAGON KEY WRENCHES

TORQUE WRENCHES

CROWFOOT WRENCHES

SOCKETS

OTHER TOOLS



Please do not use the product of this mark with the power tool including the impact wrench.

**ASAHI**  
TOOLS

# 1/2" (12.7mm) - Drive

## VTL4 T-Shape Speed Handle, Separate Type

Code	L <sub>1</sub> mm	D <sub>1</sub> mm	L <sub>2</sub> mm	D <sub>2</sub> mm	L <sub>3</sub> mm	Weight g		Price ¥
VTL0400	320	26	230	20	375	800	2	5,400

- ・ ニッケルクロムメッキ
- ・ カバー容器入

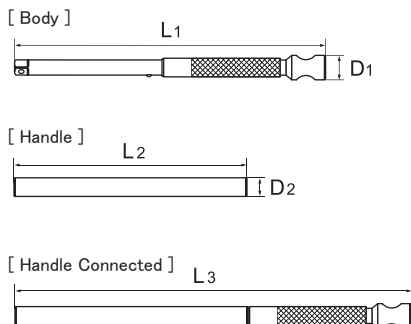

The handle can be stored in the body, so it takes up less storage space than existing T-shaped handles, making it convenient to carry around.  
The quick-turn collar enables speedy work.  
The handle slides for use in either T or L configuration, depending on work requirements.



## VU4 Universal Joint

Code	D mm	L mm	Weight g		Price ¥
VU0400	25	69	130	5	2,990

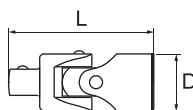
- ・ ニッケルクロムメッキ





## VA4 Adaptor

Code	 mm x mm	D mm	L mm	Weight g		Price ¥
VA4030	12.7 × 9.5	23	35	50	-	1,770
VA4060	12.7 × 19.0	25	40	115	-	2,650

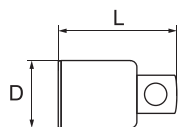
- ・ Nickel Chrome Plating



## VP4 Plug Socket

Code	 mm	A mm	D mm	L mm	Weight g		Price ¥
VP0421	21	22	27	68	145	-	1,950

- ・ Nickel Chrome Plating
- ・ The internal rubber surface secures plugs firmly

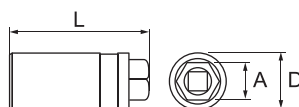

Please do not use the product of this mark with the power tool including the impact wrench.

# 1/2" (12.7mm) - Drive

## VL4 Offset Handle

Code	d mm	H mm	L mm	Weight g		Price ¥
VL0428	16	57	280	500	5	2,380

• Nickel Chrome Plating

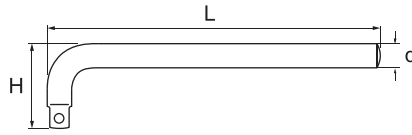

## VN4 Speeder

Code	H mm	L mm	Weight g		Price ¥
VN0440	93	415	660	5	4,670

• Nickel Chrome Plating

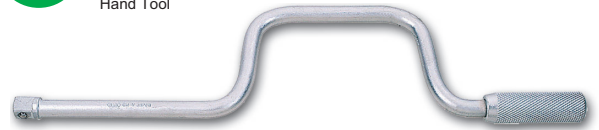
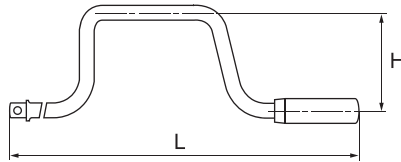

For quick turning

## VB4 Cross Bar

Code	D mm	L mm	Weight g		Price ¥
VB0425	12	250	220	-	560

• Nickel Chrome Plating

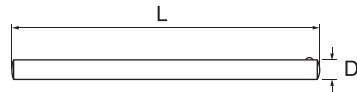

Insert a crossbar through the hole of the spinner handle and utilize as a T-handled wrench.

TOOL SETS

SPANNERS

STRIKING FACE WRENCHES

HOOK SPANNERS

DX2000 TOOLS  
HEXAGON KEY WRENCHES

HEXAGON KEY WRENCHES

TORQUE WRENCHES

CROWFOOT WRENCHES

SOCKETS

OTHER TOOLS



Please do not use the product of this mark with the power tool including the impact wrench.

# 3/4" (19.0mm) - Drive

## VO6 Socket Wrench Set, 12point, Metric

**12Pcs.**

Code **VO6080**

Price **¥65,200**

Set Contains

Socket (12point)	VS6- 26, 29, 32, 35, 38, 41, 46, 50
Ratchet Handle	VR0650
Sliding T-Handle	VT0650
Extension Bar	VE0620 (200mm) , VE0640 (400mm)

- Weight 10.2kg
- Tool Box 145 × 510 × 80mm



VO6080

**12Pcs.**

Code **VO6081**

Price **¥65,200**

Set Contains

Socket (12point)	VS6- 24, 27, 30, 32, 36, 41, 46, 50
Ratchet Handle	VR0650
Sliding T-Handle	VT0650
Extension Bar	VE0620 (200mm) , VE0640 (400mm)

- Weight 10.2kg
- Tool Box 145 × 510 × 80mm



VO6081

## VS6 Socket, Metric

Code	mm	D1 mm	D2 mm	h mm	L mm	Weight g	Price ¥
VS6190	19	30	35	18	50	200	2,050
VS6210	21	31	36	14.5	51	223	2,050
VS6220	22	32	35	17.5	51	196	2,050
VS6240	24	34	35	16	50	194	2,050
VS6260	26	36	35	20	52	195	2,140
VS6270	27	38	36	25	52	221	2,150
VS6290	29	41	38	29	55	250	2,430
VS6300	30	42	36	29	56	260	2,430
VS6320	32	43	36	26	56	276	2,520
VS6350	35	48	41	26	58	400	2,610
VS6360	36	50	42	24	58	399	2,700
VS6380	38	52	40	26	65	440	3,600
VS6410	41	55	40	28	65	490	3,920
VS6460	46	61	43	30	70	590	4,270
VS6500	50	68	42	38	70	785	5,300
VS6550	55	75	48	42	76	993	7,700

- Nickel Chrome Plating

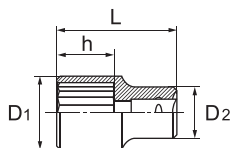

TOOL SETS

SPANNERS

STRIKING FACE WRENCHES

HOOK SPANNERS

DX2000 TOOLS  
HEXAGON KEY WRENCHES

HEXAGON KEY WRENCHES

TORQUE WRENCHES

CROWFOOT WRENCHES

SOCKETS

OTHER TOOLS



Please do not use the product of this mark with the power tool including the impact wrench.

## 3/4" (19.0mm) - Drive

### VR6 Ratchet Handle

Code	D mm	T mm	L mm	Ratcheting Angle	Weight g		Price ¥
VR0650	65	34.5	504	8°	1,800	1	15,000

- Square Drive : Cathodic Electrodeposition
- Body : Nickel Chrome Plating

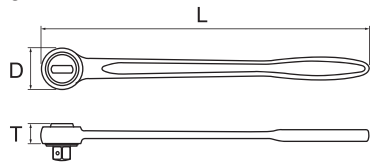

### VE6 Extension Bar

Code	D mm	L mm	Weight g		Price ¥
VE0620	35	200	580	3	3,510
VE0640	35	400	1,100	5	6,100

- Nickel Chrome Plating

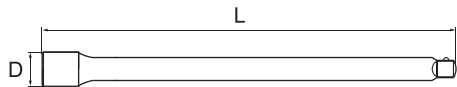

### VH6 Spinner Handle

Code	D mm	B mm	L mm	Weight g		Price ¥
VH0646	42	29	460	1,660	-	13,200

- Nickel Chrome Plating

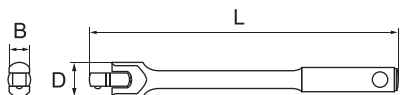

### VT6 Sliding T-Handle

Code	H mm	d mm	L mm	Weight g		Price ¥
VT0650	60	20	490	1,500	1	5,700

- Nickel Chrome Plating

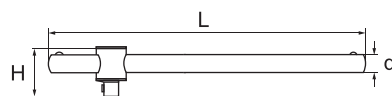

Adjust a position of a square drive for quick turning and final tightening.

## 3/4" (19.0mm) - Drive

### VU6 Universal Joint

Code	D mm	L mm	Weight g		Price ¥
VU0600	40	106	555	1	7,800

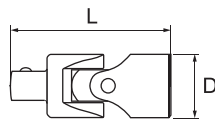

• Nickel Chrome Plating



Hand Tool



### VA6 Adaptor

Code	 mm x mm	D mm	L mm	Weight g		Price ¥
VA6040	19.0 x 12.7	36	52	224	-	4,470

• Nickel Chrome Plating

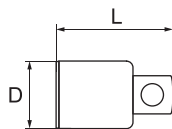

Hand Tool



### VL6 Offset Handle

Code	d mm	H mm	L mm	Weight g		Price ¥
VL0630	25	87	330	1,400	5	5,600

• Nickel Chrome Plating

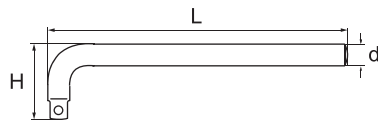

Hand Tool



TOOL SETS

SPANNERS

STRIKING FACE WRENCHES

HOOK SPANNERS

DX2000 TOOLS  
HEXAGON KEY WRENCHES

HEXAGON KEY WRENCHES

TORQUE WRENCHES

CROWFOOT WRENCHES

SOCKETS

OTHER TOOLS



Please do not use the product of this mark with the power tool including the impact wrench.

**ASAHI**  
TOOLS



# Impact Sockets

## Socket



US3 USL3 US4 USL4 US6 USL6 US8 USL8 US10

Insertion angle mm	9.5	12.7	19.0	25.4	38.1
--------------------	-----	------	------	------	------

Shape	Long	Long	Long	Long
-------	------	------	------	------

Width across flat	US3	USL3	US4	USL4	US6	USL6	US8	USL8	US10
7		●	●						
8	●	●	●						
9	●		●						
10	●	●	●	●					
11	●								
12	●	●	●	●					
13	●	●	●	●					
14	●	●	●	●					
15	●		●						
16	●		●						
17	●	●	●	●	●		●	●	
18	●								
19	●	●	●	●	●	●	●	●	
20	●								
21	●	●	●	●	●	●	●	●	
22	●	●	●	●	●	●	●	●	
23	●		●	●	●	●	●	●	
24			●	●	●	●	●	●	●
26			●	●	●	●	●	●	●
27			●	●	●	●	●	●	●
29			●		●	●	●	●	
30			●	●	●	●	●	●	●
32			●	●	●	●	●	●	●
35			●		●	●	●	●	●
36			●		●	●	●	●	●
38					●	●	●	●	●
41					●	●	●	●	●
46					●	●	●	●	●
50					●		●	●	●
54							●	●	●
55					●		●	●	●
58							●	●	●
60							●	●	●
63							●		
65							●		●
67							●		
70							●		●
71							●		
75							●		●
80							●		●
85							●		●
90							●		●
95							●		●
100							●		●
105							●		●
110							●		●
115							●		●
120							●		●

## Hex Bit Socket



UX3 UX4 UXX6 UXX8 UXX10



Insertion angle mm	9.5	12.7	19.0	25.4	38.1
--------------------	-----	------	------	------	------

Shape	Long	Long	Long	Long
-------	------	------	------	------

Width across flat	UX3	UX4	UXX6	UXX8	UXX10
3	●				
4	●				
5	●	●			
6	●	●			
8	●	●			
9.5		●			
10	●	●	●		
12	●	●	●		
12.7		●			
14		●	●	●	
17		●	●	●	
19		●	●	●	
22			●	●	●
24				●	●
27				●	●
32				●	●
36					●

# 3/8" (9.5mm) - Drive

## US3 Impact Socket, Metric



Code	 mm	D <sub>1</sub> mm	D <sub>2</sub> mm	h mm	L mm	Weight g		Price ¥
US0308	8	13	19	5	25	27	-	1,080
US0309	9	14.5	19	6	25	28	-	1,080
US0310	10	16	19	7	25	30	-	1,080
US0311	11	17.5	19	7	25	31	-	1,080
US0312	12	19	19	8	25	33	-	1,080
US0313	13	20	20	8	27	41	-	1,080
US0314	14	21.5	20	8	27	43	-	1,080
US0315	15	23	20	9	27	45	-	1,170
US0316	16	24	20	9	27	46	-	1,210
US0317	17	25.5	20	10	27	48	-	1,210
US0318	18	27	20	12	30	57	-	1,310
US0319	19	28	20	12	30	57	-	1,420
US0320	20	30	20	12	32	63	-	1,420
US0321	21	31	20	12	32	73	-	1,420
US0322	22	32	20	12	32	71	-	1,440
US0323	23	34	20	12	32	83	-	1,460

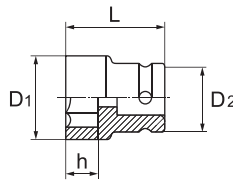

• Manganese Phosphate Treatment



## USL3 Long Impact Socket, Metric

Code	 mm	D <sub>1</sub> mm	D <sub>2</sub> mm	h mm	L mm	Weight g		Price ¥
USL0307	7	11.5	19	6	55	49	-	1,720
USL0308	8	12.5	19	7	55	54	-	1,720
USL0310	10	15.5	19	8	55	63	-	1,720
USL0312	12	18.5	20	9	55	78	-	1,720
USL0313	13	20	20	9	55	85	-	1,840
USL0314	14	21	20	11	55	86	-	1,840
USL0317	17	25	20	11	55	90	-	1,860
USL0319	19	27	20	12	55	90	-	2,030
USL0321	21	30	20	21	55	110	-	2,140
USL0322	22	32	20	21	55	120	-	2,290



• Manganese Phosphate Treatment

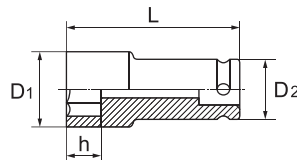

TOOL SETS  
SPANNERS  
STRIKING FACE WRENCHES  
HOOK SPANNERS  
DX2000 TOOLS  
HEXAGON KEY WRENCHES  
HEXAGON KEY WRENCHES  
TORQUE WRENCHES  
CROWFOOT WRENCHES  
SOCKETS  
OTHER TOOLS

## 3/8" (9.5mm) - Drive

### UX3 Impact Hex Bit Socket, Metric

Code	Ø mm	D mm	ℓ mm	L mm	Weight g		Price ¥
UX3003	3	19	12	50	33	-	1,440
UX3004	4	19	15	50	34	-	1,440
UX3005	5	19	17	50	35	-	1,570
UX3006	6	19	18	50	37	-	1,570
UX3008	8	20	23	50	52	-	1,670
UX3010	10	20	27	50	62	-	1,670
UX3012	12	20	30	50	74	-	1,820

• Manganese Phosphate Treatment

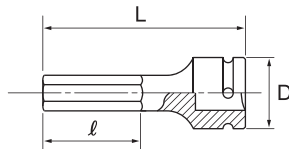

Impact Tool



### UE3 Extension Bar

Code	L mm	Weight g		Price ¥
UE0307	75	70	-	2,650
UE0310	100	90	-	2,840

• Manganese Phosphate Treatment

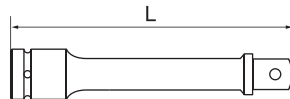

Impact Tool



### UJ3 Universal Joint

Code	L mm	Weight g		Price ¥
UJ0300	51	75	-	5,700

• Manganese Phosphate Treatment

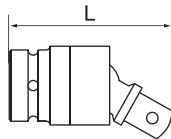

Impact Tool



### UA3 Adaptor

Code	mm x mm	L mm	Weight g		Price ¥
UA0304	9.5 x 12.7	34	55	-	2,790

• Manganese Phosphate Treatment

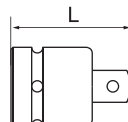

Impact Tool



TOOL SETS

SPANNERS

STRIKING FACE WRENCHES

HOOK SPANNERS

DX2000 TOOLS  
HEXAGON KEY WRENCHES

HEXAGON KEY WRENCHES

TORQUE WRENCHES



CROWFOOT WRENCHES

SOCKETS

OTHER TOOLS

# 1/2" (12.7mm) - Drive

## US4 Impact Socket, Metric

Code	 mm	D <sub>1</sub> mm	D <sub>2</sub> mm	h mm	L mm	Weight g		Price ¥
US0407	7	14	25	6	35	60	-	1,100
US0408	8	15	25	6	35	60	-	1,100
US0409	9	16	25	6	35	75	-	1,100
US0410	10	17.5	25	7	35	65	-	1,170
US0412	12	20.5	25	8	35	70	-	1,170
US0413	13	21	25	8	35	70	-	1,170
US0414	14	23	27	9	38	95	-	1,170
US0415	15	24.5	27	10	38	100	-	1,250
US0416	16	25.5	27	10	38	100	-	1,250
US0417	17	27	27	10	38	110	-	1,250
US0419	19	30	28	12	40	130	-	1,360
US0421	21	33	28	14	40	145	-	1,360
US0422	22	34	28	14	43	160	-	1,360
US0423	23	35	28	14	43	165	-	1,510
US0424	24	36.5	28	14	43	170	-	1,510
US0426	26	39	28	15	45	185	-	1,620
US0427	27	40	28	15	45	200	-	2,030
US0429	29	43	28	16	45	210	-	2,280
US0430	30	44	28	18	47	220	-	2,400
US0432	32	47	28	18	47	240	-	2,520
US0435	35	50	36	20	50	340	-	2,850
US0436	36	51	36	20	50	340	-	3,040

• Manganese Phosphate Treatment

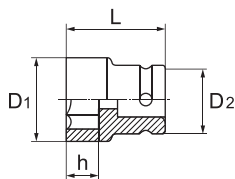



Impact Tool



6point



## USL4 Long Impact Socket, Metric

Code	 mm	D <sub>1</sub> mm	D <sub>2</sub> mm	h mm	L mm	Weight g		Price ¥
USL0410	10	14	24	15	60	75	-	1,760
USL0412	12	17	24	15	60	85	-	1,760
USL0413	13	18	24	15	60	90	-	1,760
USL0414	14	20	24	17	60	95	-	1,760
USL0417	17	24	24	17	60	120	-	1,760
USL0419	19	26	26	17	60	135	-	2,040
USL0421	21	28.5	26	17	60	155	-	2,120
USL0422	22	30	27	20	60	165	-	2,270
USL0423	23	31	28	20	60	185	-	2,270
USL0424	24	33	28	20	60	200	-	2,270
USL0426	26	35	28	20	80	270	-	2,500
USL0427	27	37	28	20	80	315	-	2,620
USL0430	30	41	28	23	80	270	-	3,070
USL0432	32	43	36	23	80	390	-	3,400

• Zinc Plating

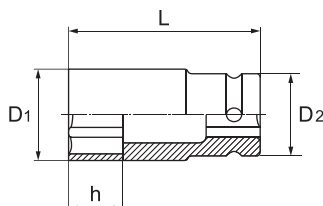

Impact Tool



6point



TOOL SETS

SPANNERS

STRIKING FACE WRENCHES

HOOK SPANNERS

DX2000 TOOLS  
HEXAGON KEY WRENCHES

HEXAGON KEY WRENCHES

TORQUE WRENCHES

CROWFOOT WRENCHES

SOCKETS

OTHER TOOLS

## 1/2" (12.7mm) - Drive

### UX4 Impact Hex Bit Socket, Metric

Code	Ø mm	D mm	ℓ mm	L mm	Weight g		Price ¥
UX4005	5	25	17	60	67	-	1,470
UX4006	6	25	18	60	70	-	1,470
UX4008	8	25	23	60	78	-	1,610
UX4009	9.5	27	27	68	108	-	1,610
UX4010	10	27	27	68	110	-	1,610
UX4012	12	27	30	68	123	-	1,700
UX4013	12.7	27	30	68	127	-	1,840
UX4014	14	28	40	78	159	-	1,840
UX4017	17	28	40	78	194	-	1,930
UX4019	19	28	40	78	222	-	2,630

- Manganese Phosphate Treatment

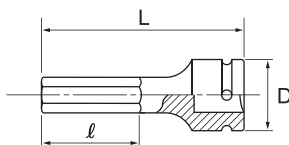

Impact Tool



### UE4 Extension Bar

Code	L mm	Weight g		Price ¥
UE0410	100	155	-	2,910
UE0415	150	220	-	3,620
UE0420	200	290	-	3,710
UE0425	250	355	-	3,840

- Manganese Phosphate Treatment

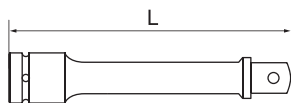

Impact Tool



### UJ4 Universal Joint

Code	L mm	Weight g		Price ¥
UJ0400	68	200	-	7,000

- Manganese Phosphate Treatment

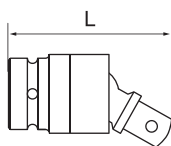

Impact Tool



### UA4 Adaptor

Code	mm × mm	L mm	Weight g		Price ¥
UA0403	12.7 × 9.5	36	65	-	2,890
UA0406	12.7 × 19.0	47	145	-	3,300

- Manganese Phosphate Treatment

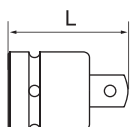

Impact Tool



TOOL SETS

SPANNERS

STRIKING FACE WRENCHES

HOOK SPANNERS

DX2000 TOOLS  
HEXAGON KEY WRENCHES

HEXAGON KEY WRENCHES

TORQUE WRENCHES

CROWFOOT WRENCHES

SOCKETS

OTHER TOOLS

## 3/4" (19.0mm) - Drive

### US6 Impact Socket, Metric

Code	mm	D <sub>1</sub> mm	D <sub>2</sub> mm	h mm	L mm	Weight g		Price ¥
US0617	17	27.5	36	10	48	195	-	2,470
US0619	19	30.5	37	12	48	220	-	2,470
US0621	21	33	37	13	50	240	-	2,470
US0622	22	34.5	37	14	50	245	-	2,470
US0623	23	36	37	14	50	260	-	2,560
US0624	24	38	38	14	53	300	-	2,560
US0626	26	40	38	15	53	310	-	2,620
US0627	27	42	38	15	53	325	-	2,620
US0629	29	44	38	16	55	360	-	2,940
US0630	30	46	38	16	55	380	-	2,940
US0632	32	49	38	18	55	385	-	2,940
US0635	35	53	38	22	58	450	-	3,280
US0636	36	54.5	38	22	58	470	-	3,280
US0638	38	58	38	23	60	550	-	4,090
US0641	41	62	44	23	60	655	-	4,320
US0646	46	68	44	26	60	790	-	5,900
US0650	50	73	44	28	70	900	-	8,000
US0655	55	78	54	30	74	1,310	-	12,200

• Manganese Phosphate Treatment

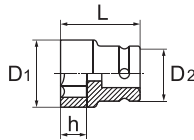

Impact Tool 6point



### USL6 Long Impact Socket, Metric

Code	mm	D <sub>1</sub> mm	D <sub>2</sub> mm	h mm	L mm	Weight g		Price ¥
USL0619	19	29	37	22	100	410	-	4,050
USL0621	21	32	37	22	100	450	-	4,050
USL0622	22	33	37	23	100	455	-	4,050
USL0623	23	34.5	37	23	100	490	-	4,220
USL0624	24	36	37	25	100	500	-	4,220
USL0626	26	40	38	25	100	580	-	4,560
USL0627	27	41	38	26	100	575	-	4,560
USL0630	30	44	38	26	100	570	-	5,200
USL0632	32	47.5	38	26	100	585	-	5,400
USL0635	35	51.5	38	26	100	610	-	5,900
USL0636	36	52	38	26	100	610	-	6,200
USL0638	38	55.5	38	28	100	680	-	7,200
USL0641	41	59	44	28	100	885	-	8,100
USL0646	46	65	44	31	100	930	-	10,100

• Manganese Phosphate Treatment

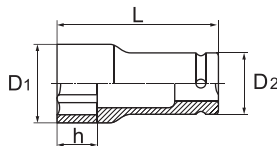

Impact Tool 6point



### UE6 Extension Bar

Code	L mm	Weight g		Price ¥
UE0610	100	400	-	5,600
UE0615	150	545	-	5,900
UE0620	200	700	-	6,700
UE0625	250	840	-	7,900

• Manganese Phosphate Treatment

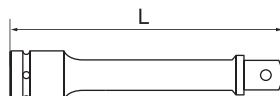

Impact Tool



TOOL SETS

SPANNERS

STRIKING FACE WRENCHES

HOOK SPANNERS

DX2000 TOOLS  
HEXAGON KEY WRENCHES

HEXAGON KEY WRENCHES

TORQUE WRENCHES

GROUNDFOOT WRENCHES

SOCKETS

OTHER TOOLS

## 3/4" (19.0mm) - Drive

### UXX6 Impact Hex Bit Socket, Metric

Code	Ø mm	B mm	D mm	ℓ mm	L mm	Weight g		Price ¥
UXX0610	10	22	44	32	90	540	-	6,380
UXX0612	12	22	44	32	90	545	-	6,380
UXX0614	14	22	44	32	90	555	-	6,380
UXX0617	17	22	44	32	90	570	-	6,380
UXX0619	19	22	44	32	90	580	-	6,380
UXX0622	22	22	44	32	90	620	-	7,480

- Body : Cathodic Electrodeposition
- Hex : Black Oxide Finish

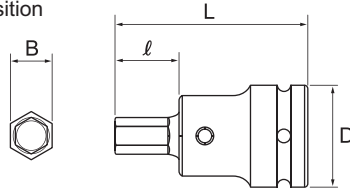

### 【 Exchange Bit 】

Code	Ø mm	D mm	L mm	Weight g		Price ¥
UXT0610	10	22	57	120	-	2,290
UXT0612	12	22	57	124	-	2,290
UXT0614	14	22	57	136	-	2,290
UXT0617	17	22	57	154	-	2,290
UXT0619	19	22	57	168	-	2,290
UXT0622	22	22	57	188	-	3,430

- For UXX6
- Black Oxide Finish

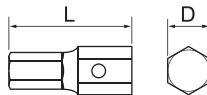

### UJ6 Universal Joint

Code	L mm	重量 g	箱入数	小売価格 ¥
UJ0600	112	800	-	10,800

- Manganese Phosphate Treatment

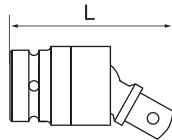

### UA6 Adaptor

Code	mm × mm	L mm	Weight g		Price ¥
UA0604	19.0 × 12.7	50	190	-	3,500
UA0604L	19.0 × 12.7	150	404	-	6,100
UA0608	19.0 × 25.4	61	990	-	5,500

- Manganese Phosphate Treatment

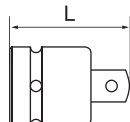

TOOL SETS

SPANNERS

STRIKING FACE WRENCHES

HOOK SPANNERS

DX2000 TOOLS  
HEXAGON KEY WRENCHES

HEXAGON KEY WRENCHES

TORQUE WRENCHES



CROWFOOT WRENCHES

SOCKETS

OTHER TOOLS

# 1" (25.4 mm) - Drive

## US8 Impact Socket, Metric

Code	 mm	D <sub>1</sub> mm	D <sub>2</sub> mm	h mm	L mm	Weight g		Price ¥
US0817	17	31	48	12	57	400	-	4,580
US0819	19	33.5	48	12	57	400	-	4,580
US0821	21	36	48	13	57	420	-	4,580
US0822	22	37.5	48	14	57	425	-	4,580
US0823	23	38.5	48	14	57	430	-	4,580
US0824	24	40	48	14	57	440	-	4,580
US0826	26	43	49	15	57	470	-	4,580
US0827	27	45	49	15	60	520	-	4,580
US0829	29	47	49	16	60	530	-	4,580
US0830	30	49	49	16	62	580	-	4,580
US0832	32	52	52	18	62	575	-	4,580
US0835	35	55	52	19	62	765	-	5,000
US0836	36	56	52	19	62	780	-	5,000
US0838	38	59	52	26	68	790	-	5,600
US0841	41	63	52	26	68	790	-	5,900
US0846	46	69	52	26	72	960	-	7,500
US0850	50	73	52	28	75	1,000	-	9,200
US0854	54	78	60	31	80	1,400	-	10,600
US0855	55	80	60	31	80	1,450	-	11,800
US0858	58	83	60	31	80	1,450	-	13,900
US0860	60	86	60	32	80	1,560	-	15,900
US0863	63	90	60	34	80	1,550	-	17,100
US0865	65	92	60	36	85	1,800	-	19,100
US0867	67	95	60	37	85	1,800	-	25,200
US0870	70	97	60	40	90	2,000	-	27,100
US0871	71	98	60	40	90	2,420	-	29,500
US0875	75	103	60	44	95	2,200	-	32,000
US0880	80	110	60	48	100	2,460	-	42,300
US0885	85	116	66	51	105	2,920	-	48,400
US0890	90	122	66	54	110	3,250	-	58,100
US0895	95	135	80	57	115	3,270	-	65,000



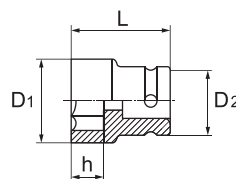

Impact Tool 6point



• Manganese Phosphate Treatment

## USL8 Long Impact Socket, Metric

Code	 mm	D <sub>1</sub> mm	D <sub>2</sub> mm	h mm	L mm	Weight g		Price ¥
USL0817	17	30	49	20	100	760	-	7,100
USL0819	19	32	49	23	100	780	-	7,100
USL0821	21	35	49	23	100	800	-	7,100
USL0822	22	36	49	23	100	800	-	7,100
USL0824	24	38	49	25	100	800	-	7,100
USL0826	26	41	49	25	100	900	-	7,100
USL0827	27	42	49	26	100	900	-	7,100
USL0830	30	46	52	26	100	900	-	7,100
USL0832	32	48	52	26	100	940	-	7,100
USL0835	35	52	52	26	100	1,030	-	7,600
USL0836	36	54	52	30	100	1,070	-	7,600
USL0838	38	56	52	30	100	1,100	-	8,800
USL0841	41	59	52	35	100	1,100	-	10,000
USL0846	46	66	52	35	100	1,140	-	11,800
USL0850	50	70	52	35	100	1,300	-	15,500
USL0854	54	77	60	35	110	1,600	-	15,900
USL0855	55	78	60	35	110	1,600	-	18,100
USL0858	58	81.5	60	37	110	1,850	-	18,900
USL0860	60	84	60	37	110	1,950	-	22,600



Impact Tool 6point

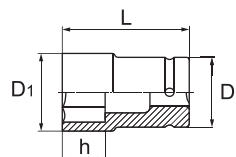

• Manganese Phosphate Treatment

TOOL SETS  
SPANNERS  
STRIKING FACE WRENCHES  
HOOK SPANNERS  
DX2000 TOOLS  
HEXAGON KEY WRENCHES  
HEXAGON KEY WRENCHES  
TORQUE WRENCHES  
CROWFOOT WRENCHES  
SOCKETS  
OTHER TOOLS



# 1" (25.4 mm) - Drive

## UE8 Extension Bar

Code	L mm	Weight g		Price ¥
UE0816	160	1,060	-	9,000
UE0820	200	1,300	-	10,000
UE0825	250	1,543	-	11,200
UE0830	300	1,800	-	11,600

- Manganese Phosphate Treatment

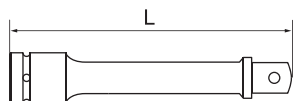

## UXX8 Impact Hex Bit Socket, Metric

Code	Ø mm	B mm	D mm	ℓ mm	L mm	Weight g		Price ¥
UXX0814	14	32	54	40	115	1,240	-	11,110
UXX0817	17	32	54	40	115	1,260	-	11,110
UXX0819	19	32	54	40	115	1,275	-	11,110
UXX0822	22	32	54	40	115	1,300	-	12,760
UXX0824	24	32	54	40	115	1,320	-	15,620
UXX0827	27	32	54	40	115	1,355	-	18,040
UXX0832	32	32	54	40	115	1,420	-	19,910

- Body : Cathodic Electrodeposition B
- Hex : Black Oxide Finish

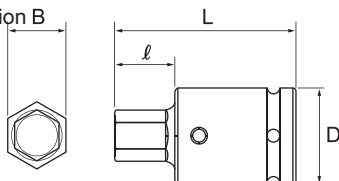

## 【 Exchange Bit 】

Code	Ø mm	D mm	L mm	Weight g		Price ¥
UXT0814	14	32	75	330	-	3,890
UXT0817	17	32	75	358	-	3,890
UXT0819	19	32	75	376	-	3,890
UXT0822	22	32	75	404	-	5,610
UXT0824	24	32	75	422	-	8,360
UXT0827	27	32	75	458	-	10,890
UXT0832	32	32	75	524	-	12,760

- For UXX6
- Black Oxide Finish

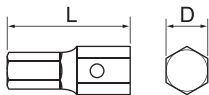

## UJ8 Universal Joint

Code	L mm	Weight g		Price ¥
UJ0800	128	1,300	-	15,900

- Manganese Phosphate Treatment

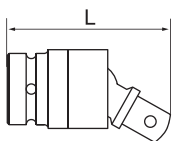

TOOL SETS

SPANNERS

STRIKING FACE WRENCHES

HOOK SPANNERS

DX2000 TOOLS  
HEXAGON KEY WRENCHES

HEXAGON KEY WRENCHES

TORQUE WRENCHES

CROWFOOT WRENCHES

SOCKETS

OTHER TOOLS

## 1" (25.4 mm) - Drive

### UA8 Adaptor

Code	mm × mm	L mm	Weight g		Price ¥
UA0806	25.4 × 19.0	64	430	-	5,500
UA0810	25.4 × 38.1	81	870	-	17,400

• Manganese Phosphate Treatment

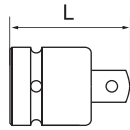

Impact Tool



## 1-1/2" (38.1 mm) - Drive

### US10 Impact Socket, Metric

Code	mm	D1 mm	D2 mm	h mm	L mm	Weight g		Price ¥
US1050	50	79	79	32	85	1,950	-	26,300
US1055	55	85	80	35	90	2,200	-	28,100
US1060	60	92	80	37	95	2,600	-	33,700
US1065	65	98	80	40	100	2,900	-	39,200
US1070	70	104	80	42	100	3,850	-	48,300
US1075	75	109	80	44	105	3,300	-	60,200
US1080	80	115	85	48	110	3,800	-	78,400
US1085	85	122	85	51	115	4,400	-	80,300
US1090	90	128	85	54	120	5,000	-	87,800
US1095	95	135	85	57	125	5,500	-	91,000
US1100	100	139	85	58	130	8,500	-	104,900
US1105	105	148	85	62	135	7,000	-	114,600
US1110	110	153	85	65	137	7,600	-	126,500
US1115	115	160	90	67	140	8,500	-	138,700
US1120	120	168	90	70	145	10,000	-	152,900

• Manganese Phosphate Treatment

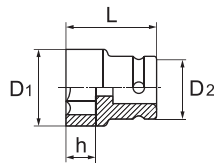

Impact Tool

6point



### UA10 Adaptor

Code	mm × mm	L mm	Weight g		Price ¥
UA1008	38.1 × 25.4	90	1,300	-	19,600

• Manganese Phosphate Treatment

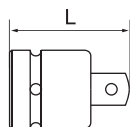

Impact Tool



TOOL SETS  
SPANNERS  
STRIKING FACE WRENCHES  
HOOK SPANNERS  
DX2000 TOOLS  
HEXAGON KEY WRENCHES  
HEXAGON WRENCHES  
TORQUE WRENCHES  
CROWFOOT WRENCHES  
SOCKETS  
OTHER TOOLS

# 1-1/2" (38.1mm) - Drive

## UXX10 Impact Hex Bit Socket, Metric

Code	Ø mm	B mm	D mm	ℓ mm	L mm	Weight g		Price ¥
UXX1022	22	27	83	35	125	2,600	-	35,300
UXX1024	24	27	83	35	125	2,620	-	35,300
UXX1027	27	27	83	35	125	2,690	-	35,300
UXX1032	32	36	83	37	127	3,280	-	38,300
UXX1036	36	36	83	37	127	3,350	-	40,000



Impact Tool

- Body : Cathodic Electrodeposition
- Hex : Black Oxide Finish

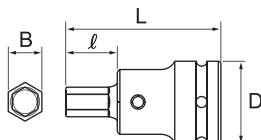

### 【 Exchange Bit 】

Code	Ø mm	D mm	L mm	Weight g		Price ¥
UXT1022	22	27	70	300	-	7,200
UXT1024	24	27	70	320	-	7,200
UXT1027	27	27	70	350	-	7,200
UXT1032	32	36	72	582	-	10,200
UXT1036	36	36	72	644	-	11,900

- For UXX10
- Black Oxide Finish

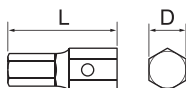

## UO UP O-Ring, Pin For Impact Socket



Impact Tool



O-Ring			Pin			Use With
Code	W mm	D mm	Code	D mm	L mm	
UO0300	2.4	14.8	UP0300	2.8	16.5	US3, USL3, UX3, UE3, UJ3, UA3
UO0400	3.5	20.2	UP0400	3.5	21	US4-7~13, USL4-10~22, UX4, UA4
UO0440	3.5	22.1	UP0440	3.5	24.5	US4-14~32, USL4-23~30, UE4, UJ4
UO0600	3.5	31.7	UP0460	3.5	32	US4-35~36, USL4-32
			UP0600	4	33.5	US6-17~38, USL6-19~38, UE6, UJ6, UA6
UO0660	3.5	37.7	UP0660	4	39	US6-41~50, USL6-41~46, UXX6
UO0800	5	44	UP0800	5	44.5	US6-55, US8-17~50, USL8-17~50, UE8, UJ8, UA8, UXX8
UO0850	3	49.6	UP0820	5	52	US8-54~80, USL8-54~60
UO0880	5.5	57.8	UP0840	5	58	US8-85~90
			UP1000	7	64	UA10
UO1000	5.5	69	UP1050	7	71	US10-50~110, UXX10
UO1100	5.5	79.4	UP0860	5	71	US8-95
			UP1100	7	81	US10-115~120

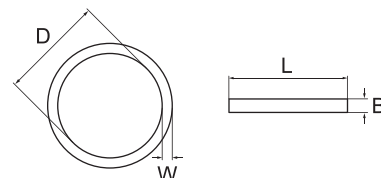

# AC Oilcan Cock

Code	D	H mm	Weight kg		Price ¥
AC6100	G2	232	1.4	10	19,700

• Zinc alloy (aluminum alloy flange)

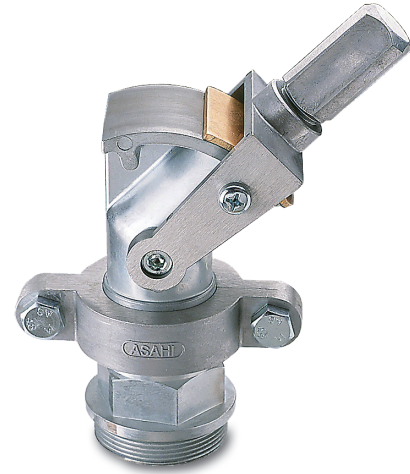
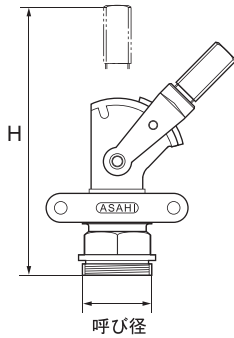

- Attach to an oil can, which is compatible for a JIS type G2 screw, and utilize as a cock.
- Please use for thickened noninflammable oil.
- It can be used for oil of non-flammable viscosity grade ISO VG32.
- Do not use for inflammable oils, paraffin oils, heavy fuel oils, petrol, chemicals, acid and alkaline solutions, solvents, aroma chemicals, paints, inks, and cooking oils. This product is not designed for the use of these materials.
- Please watch out for fire.
- The packing (large) is not included.

### [ How to use ]



Put on a cock to an oil tank.



Move the grip up or down to open or close the cock.

### AC6100 Parts List

No.	Parts	Code
①	Grip	TFACN
②	Handle	TFACH
③	Hex socket head cap bolt	
④	Phillips screw	TFACS
⑤	Spring	
⑥	Parts for fixing	TFACB
⑦	Bolt	
⑧	Nut	
⑨	Body / Nipple	TFAC6
⑩	Packing / Small	TFACPS
⑪	Packing / Large	TFACPL

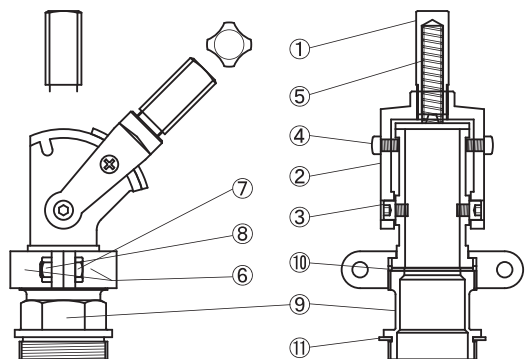

# AB Oilcan Spanner

Code	A mm	B mm	C mm	D mm	E mm	Weight g	Price ¥
	F mm	G mm	H mm	I mm	L mm		
AB5100	76	29	31	16.5	□25	1,080	10
	49	41	39	39	420		

• Black Oxide Finish

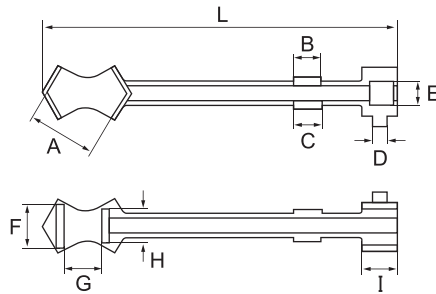

## 【 How to use 】

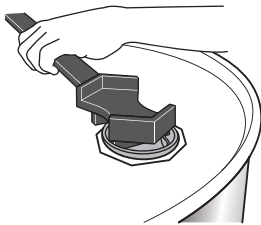

- For loosening or tightening a cap of a drum.
- Suitable for various kinds of caps.
- Insert an applicable size prong to a drum cap.
- Suitable for various kinds of caps.

## 【 Example of use 】

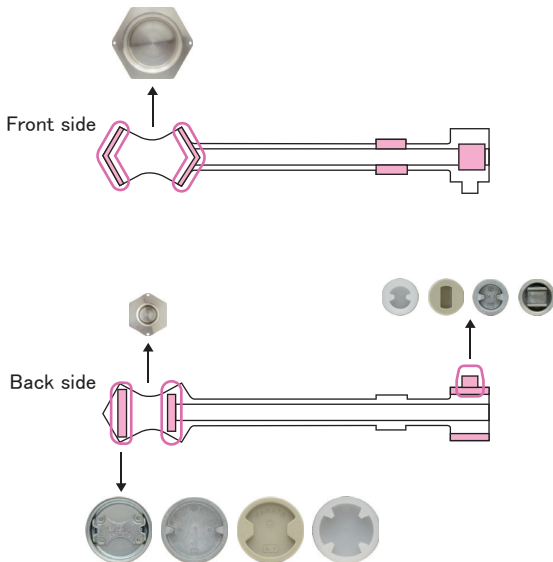

TOOL SETS  
 SPANNERS  
 STRIKING FACE WRENCHES  
 HOOK SPANNERS  
 DX2000 TOOLS  
 HEXAGON KEY WRENCHES  
 HEXAGON KEY WRENCHES  
 TORQUE WRENCHES  
 CROWFOOT WRENCHES  
 SOCKETS  
 OTHER TOOLS

## TB T-Handled Wrench, 6point, Metric

Code	mm	D mm	T mm	L <sub>1</sub> mm	L <sub>2</sub> mm	d mm	Weight g	Price ¥
TB0006	6	10	11	110	100	8	80	950
TB0007	7	12	11	110	100	8	85	840
TB0008	8	13	11	110	100	8	85	840
TB0009	9	14	11	110	100	8	90	1,090
TB0010	10	15.5	13	150	135	8	120	790
TB0011	11	17	15	150	135	10	195	1,090
TB0012	12	18	16	160	160	10	210	890
TB0013	13	19	17	160	160	10	210	970
TB0014	14	21	18	160	160	10	227	970
TB0017	17	24.5	20	180	180	11	295	1,010
TB0019	19	28	24	200	190	13	440	1,410
TB0021	21	30	25	210	200	13	465	1,450
TB0022	22	32	27	210	200	13	510	2,030
TB0024	24	34	29	235	220	14	650	2,190
TB0026	26	38	32	250	240	16	860	2,250
TB0027	27	38	33	250	240	16	850	3,470
TB0030	30	44	37	265	250	19	1,225	3,380
TB0032	32	44	39	270	250	19	1,300	3,700
TB0036	36	50	44	290	280	22	1,810	5,200
TB0041	41	58	45	310	300	25	2,800	5,300
TB0046	46	61	46	320	340	28	2,860	11,000
TB0050	50	66	56	360	380	28	3,420	16,000
TB0055	55	73	60	380	400	28	4,420	23,200

- Nickel Chrome Plating ( ~ 0041 )
- Cathodic Electrodeposition (0046 ~ )

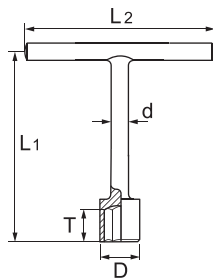

## TW Long T-Handled Wrench, 6point, Metric

Code	mm	D mm	T mm	L <sub>1</sub> mm	L <sub>2</sub> mm	d mm	Weight g	Price ¥
TW0008	8	13	11	250	200	8	180	1,160
TW0010	10	15.5	13	250	200	10	280	1,160
TW0012	12	18	16	250	200	12	395	1,250
TW0013	13	19	17	250	200	12	400	1,330
TW0014	14	21	18	270	220	12	440	1,420
TW0017	17	25	20	270	220	13	530	1,500
TW0019	19	28	23	300	250	14	700	1,810

- Nickel Chrome Plating

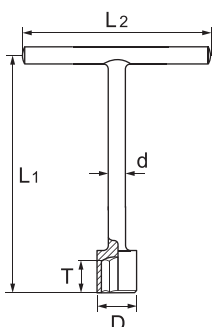

TOOL SETS  
 SPANNERS  
 STRIKING FACE WRENCHES  
 HOOK SPANNERS  
 DX2000 TOOLS  
 HEXAGON KEY WRENCHES  
 HEXAGON KEY WRENCHES  
 TORQUE WRENCHES  
 CROWFOOT WRENCHES  
 SOCKETS  
 OTHER TOOLS

## BB T-Handle Wrench, Square Drive, Metric

Code	mm	D mm	T mm	L <sub>1</sub> mm	L <sub>2</sub> mm	d mm	Weight g	Price ¥
BB0008	8	16	12	76	80	6	80	1,430
BB0010	10	19	16	106	90	9	150	1,710
BB0012	12	23	18	112	110	9	190	1,840
BB0013	13	23	18	117	110	9	190	1,870
BB0014	14	26	20	126	130	10	215	2,390

• Nickel Chrome Plating

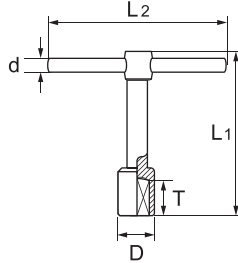

Square



## YB Y-Shape Wrench, 6point, Metric

Code	mm	d mm	D <sub>1</sub> mm	D <sub>2</sub> mm	D <sub>3</sub> mm	L mm	Weight g	Price ¥
YB0810	8×9×10	8	13	14	15.5	80	120	1,620
YB1014	10×12×14	10	15.5	18	21	85	185	1,810
YB1017	10×14×17	11	15.5	21	24.5	95	230	2,810
YB1217	12×14×17	11	18	21	24.5	95	270	2,490
YB1319	13×17×19	13	19	25	28	105	390	2,810
YB1419	14×17×19	13	21	25	28	105	400	2,870
YB1421	14×17×21	13	21	25	30	110	400	2,870
YB1721	17×19×21	13	25	28	30	115	450	3,290
YB1923	19×21×23	13	28	30	33	120	550	4,390

• Nickel Chrome Plating

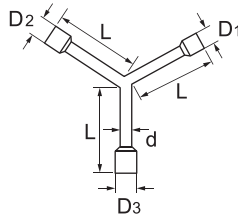

6point

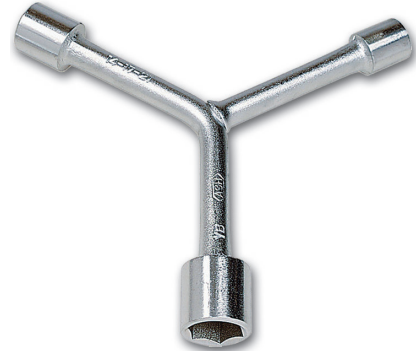

## LB Tire Wrench, 6point, Metric

Code	mm	D mm	T mm	A mm	L mm	d mm	Weight g	Price ¥
LB0008	8	13	11	30	110	8	55	1,140
LB0010	10	15.5	13	30	180	8	90	830
LB0012	12	18	16	35	190	10	140	970
LB0013	13	19	17	37	190	10	150	920
LB0014	14	21	18	37	200	10	165	1,010
LB0017	17	24.5	20	45	220	11	225	1,010
LB0019	19	28	24	50	230	13	325	1,390
LB0021	21	30	25	50	250	13	370	1,430
LB0022	22	32	27	55	255	13	375	1,870
LB0024	24	34	29	57	265	14	460	2,020
LB0026	26	38	32	63	270	16	610	2,250
LB0027	27	38	33	63	275	16	610	2,970
LB0030	30	44	37	75	280	19	900	3,100
LB0032	32	44	39	75	280	19	850	3,490
LB0036	36	50	44	82	330	22	1,360	4,390
LB0041	41	58	46	90	350	25	1,550	4,760

• Nickel Chrome Plating ( ~ 0036)  
• Parkerizing (0041)



6point

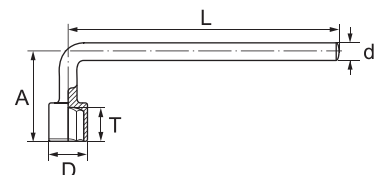

TOOL SETS

SPANNERS

STRIKING FACE WRENCHES

HOOK SPANNERS

DX2000 TOOLS  
HEXAGON KEY WRENCHES

HEXAGON KEY WRENCHES

TORQUE WRENCHES

CROWFOOT WRENCHES

SOCKETS

OTHER TOOLS

## PP Combination Plier

Code	Type	C mm	L mm	Weight g		Price ¥
PP0150	150	9	165	120	5	1,630
PP0200	200	11	203	350	5	1,870

- Nickel Chrome Plating

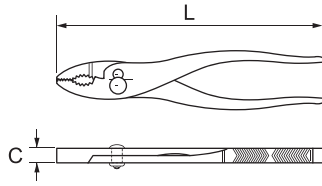

## PPW Water Pump Plier

Code	Max. mm	C mm	L mm	Weight g		Price ¥
PPW0250	47	10	252	340	1	3,070

- Nickel Chrome Plating
- Plastisol grip

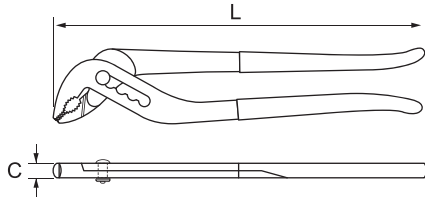

## HP Ball Pin Hammer

Code	Size lb	H mm	L mm	Weight g		Price ¥
HP0350	3/4	94	300	450	-	2,430
HP0450	1	102	320	590	10	2,430
HP0650	1-1/2	116	340	850	10	3,510

- Black Oxide Finish

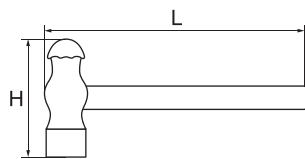

## HO Picking Hammer

Code	Size lb	H mm	L mm	Weight g		Price ¥
HO0100	1/4	107	390	110	10	2,370
HO0250	1/2	122	420	230	10	2,470

- Black Oxide Finish

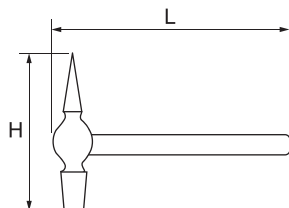

TOOL SETS

SPANNERS

STRIKING FACE WRENCHES

HOOK SPANNERS

DX2000 TOOLS  
HEXAGON KEY WRENCHES

HEXAGON KEY WRENCHES

TORQUE WRENCHES

CROWFOOT WRENCHES

SOCKETS

OTHER TOOLS



## KS Ratchet

Code	mm	C mm	T mm	d mm	L mm	Gear	Weight g		Price ¥
KS0017	17	36	35	13	220	12	330	2	7,500
KS0019	19	42	42	15	270	12	550	2	8,500
KS0021	21	42	42	15	270	12	550	2	8,500
KS0022	22	42	42	15	270	12	550	2	8,800
KS0024	24	49	48	18	325	12	880	2	9,300
KS0026	26	49	48	18	325	12	880	2	9,300
KS0027	27	49	48	18	325	12	880	2	10,800
KS0030	30	57	53	20	430	12	1,450	2	10,800
KS0032	32	57	53	20	430	12	1,450	2	10,800
KS0035	35	67	60	24	535	12	2,500	2	14,600
KS0036	36	67	60	24	535	12	2,500	2	14,900
KS0041	41	72	60	24	560	12	2,520	2	15,200
KS0046	46	82	65	26	590	14	3,400	2	20,400
KS0050	50	87	65	28	645	14	4,000	2	22,700
KS0055	55	97	65	30	760	16	5,500	-	34,400
KS0060	60	102	70	32	800	16	6,500	-	45,300
KS0065	65	113	75	34	910	16	7,000	-	65,700
KS0070	70	122	80	38.1	910	16	8,300	-	81,100
KS0075	75	130	80	38.1	965	16	9,000	-	108,200
KS0080	80	143	80	48.6	1,160	18	13,000	-	158,300

- Special Order (0060 ~ )
- Baking Finish

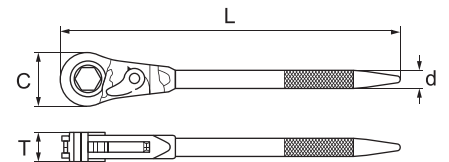

## KL Ratchet, Reversible Type

Code	mm	C mm	T mm	d mm	L mm	Gear	Weight g		Price ¥
KL0010	10	28	17	12	200	10	210	3	8,400
KL0012	12	36	20	13	245	10	350	3	8,700
KL0013	13	36	20	13	245	10	350	3	8,800
KL0014	14	42	24	15	295	10	550	3	9,300
KL0016	16	42	24	15	295	10	520	3	9,800
KL0017	17	49	28	16	385	10	850	3	10,600
KL0019	19	49	28	20	385	10	880	3	11,200
KL0022	22	57	30	22	400	10	1,400	3	13,400
KL0024	24	67	32	24	500	10	2,150	3	16,100
KL0025	25	67	32	24	500	10	2,300	3	16,100

- Cathodic Electrodeposition ( ~ 0019)
- Electrostatic coating (0022 ~ )

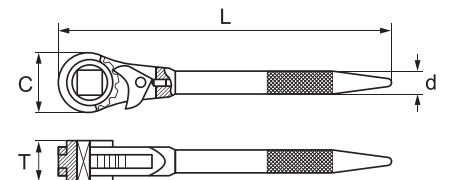

## KKL Ratchet

Code	mm	C mm	T mm	d mm	L mm	Gear	Weight g		Price ¥
KKL0013	13	36	20	13	220	12	320	3	8,800
KKL0016	16	42	24	15	270	12	520	3	9,800
KKL0019	19	49	28	18	325	12	860	3	11,200
KKL0022	22	57	30	20	430	12	1,400	3	13,400
KKL0025	25	67	32	24	535	12	2,300	3	16,100
KKL0028	28	72	33	24	555	14	2,500	3	24,400
KKL0032	32	82	37	26	590	14	3,270	3	24,700

- Baking Finish

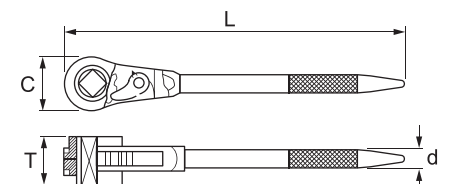

TOOL SETS

SPANNERS

STRIKING FACE WRENCHES

HOOK SPANNERS

DX2000 TOOL SETS  
HEXAGON KEY WRENCHES

HEXAGON KEY WRENCHES

TORQUE WRENCHES

CROWFOOT WRENCHES

SOCKETS

OTHER TOOLS

## SMS Double Open End Spanner Set, Metric

**6Pcs.**

Code **SMS621H**

Price **¥4,810**

Set Contains

Double Open End Spanner SM- 8×10, 11×13, 12×14, 14×17, 17×19, 22×24

- Weight 640g
- Number of boxes : 25
- Plastic Holder
- Nickel Chrome Plating



## SNT Combination Wrench Set, Metric

**6Pcs.**

Code **SNT110H**

Price **¥3,800**

Set Contains

Combination Wrench 8, 10, 12, 13, 14, 17

- Weight 640g
- Number of boxes : 30
- Plastic Holder
- Nickel Chrome Plating



## SNT Offset Wrench Set, Metric

**6Pcs.**

Code **SNT621H**

Price **¥8,860**

Set Contains

Offset Wrench 8×10, 11×13, 12×14, 14×17, 17×19, 22×24

- Weight 1,050g
- Number of boxes : 15
- Plastic Holder
- Nickel Chrome Plating



TOOL SETS

SPANNERS

STRIKING FACE WRENCHES

HOOK SPANNERS

DX2000 TOOLS  
HEXAGON KEY WRENCHES

HEXAGON KEY WRENCHES

TORQUE WRENCHES

CROWFOOT WRENCHES

SOCKETS

OTHER TOOLS

## SN Single End Spanner, Metric

Code	mm	C mm	T mm	L mm	Weight g		Price ¥
SN0010	10	23.4	4	105	20	20	400
SN0012	12	27.5	4.5	125	40	20	400
SN0013	13	30	4.5	130	45	20	400
SN0014	14	33	5	140	45	20	470
SN0017	17	38	5.5	160	85	20	530
SN0019	19	41.5	6.5	180	115	20	660
SN0022	22	47	7.5	195	140	20	830
SN0024	24	50	8.5	215	200	20	1,040
SN0026	26	56	9.5	235	250	20	1,090
SN0027	27	56	9.5	235	250	20	1,160
SN0030	30	65	10.5	275	320	10	1,420
SN0032	32	65	10.5	275	370	10	1,540
SN0035	35	74	12	305	550	10	2,390
SN0036	36	74	12	305	550	10	2,370
SN0038	38	74	12	305	550	10	3,190
SN0041	41	83	14	345	820	10	2,850
SN0046	46	92	16	385	1,200	5	4,250
SN0050	50	97	17	415	1,260	5	5,200
SN0055	55	115	18	483	2,000	5	9,140
SN0060	60	115	18	483	2,000	5	12,040
SN0065	65	140	18	575	3,000	2	15,450
SN0070	70	140	18	575	3,000	2	20,870
SN0075	75	140	18	575	3,000	2	23,760

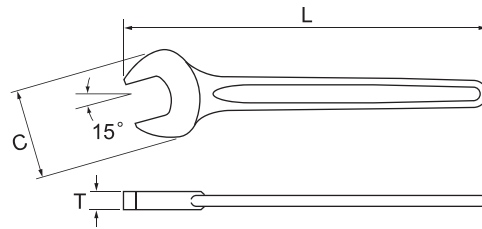

• Cathodic Electrodeposition NIS JQA (~ 0070)

## SN Double Open End Spanner, Metric

Code	mm	C <sub>1</sub> mm	C <sub>2</sub> mm	T mm	L mm	Weight g		Price ¥
SN0507	5.5×7	16	19	3.5	102	20	20	480
SN0607	6×7	16	19	3.5	102	20	20	480
SN0708	7×8	17	21	4	105	25	20	480
SN0809	8×9	19	21.5	4	115	30	20	480
SN0810	8×10	19	21.5	4	115	30	20	480
SN0910	9×10	19	21.5	4	115	30	20	480
SN1012	10×12	21.5	26	4.5	125	40	20	480
SN1013	10×13	23	27.5	5	130	50	20	480
SN1014	10×14	25	31.5	5.5	140	70	20	560
SN1113	11×13	23	27.5	5	130	50	20	520
SN1214	12×14	25	31.5	5.5	140	70	20	520
SN1317	13×17	32	37.5	6	160	100	20	580
SN1417	14×17	32	37.5	6	160	100	20	580
SN1618	16×18	37.5	41.5	6.5	180	100	20	650
SN1719	17×19	37.5	41.5	6.5	180	140	20	680
SN1921	19×21	40	46	7.5	195	170	20	860
SN1922	19×22	40	46	7.5	195	170	20	870
SN1924	19×24	44	50	8.5	215	220	20	1,020
SN2123	21×23	44	48.5	8	205	200	20	1,120
SN2126	21×26	46	55	9	225	280	10	1,120
SN2224	22×24	44	50	8.5	215	230	20	1,100
SN2326	23×26	46	55	9	225	280	10	1,420
SN2427	24×27	50	56	9.5	235	330	10	1,490
SN2430	24×30	50	60	9.5	257	360	10	1,650
SN2730	27×30	56	65	10.5	265	440	10	1,810
SN3032	30×32	63	66	11	275	510	10	2,390
SN3236	32×36	66	74	12	305	650	10	2,950
SN3541	35×41	74	83	14	345	930	5	3,720
SN3641	36×41	74	83	14	345	950	5	4,390
SN4146	41×46	87	97	16	385	1,450	5	6,250

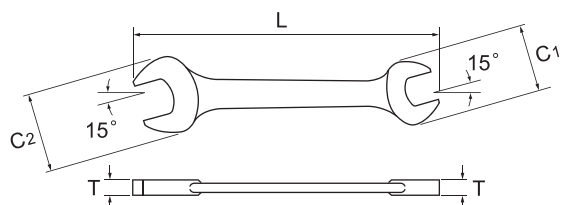

• Cathodic Electrodeposition NIS JQA

**ASAHI** TOOLS **Asahi Metal Industry Co.,Ltd**  
<https://www.asahi-tool.co.jp/>

**Head Office**

1444-1, Yoshidashimonakano, Tsubame-shi, Niigata, 959-0215, Japan  
Tel: +81-256-92-7121

**Tokyo Office**

HonjoadumabasiDJ Bld.5F, 4-19-3, Honjo, Sumida-ku, Tokyo, 130-0004, Japan  
Tel: +81-3-3621-1051

**Osaka Office**

Toua Bld.9F, 4-5-7, Minamihommachi, Chuo-ku Osaka-shi, Osaka, 541-0054, Japan  
Tel: +81-6-6282-5520

**Fukuoka Office**

9-16, Goguchimachi, Higashi-ku Fukuoka-shi, Fukuoka, 812-0069, Japan  
Tel: +81-92-611-8968

**Trade Department**

Toua Bld.9F, 4-5-7, Minamihommachi, Chuo-ku Osaka-shi, Osaka, 541-0054, Japan  
Tel: +81-6-6282-5521

- The price of this catalog does not include consumption tax.
- For the purpose of product improvement, specifications are subject to change without notice.